



RESEARCH DEPARTMENT

**Pulse – code modulation
for high – quality
sound – signal distribution:
appraisal of system requirements**

RESEARCH REPORT No. EL-10

UDC 534.86: 621.376.56

1967/50

THE BRITISH BROADCASTING CORPORATION
ENGINEERING DIVISION

RESEARCH DEPARTMENT

**PULSE-CODE MODULATION FOR HIGH-QUALITY SOUND-SIGNAL
DISTRIBUTION: APPRAISAL OF SYSTEM REQUIREMENTS**

Research Report No. EL-10
UDC 534.86: 1967/50
621.376.56

D. Howorth, B.Sc.(Tech.), A.M.C.T., M.I.E.E.
D.E.L. Shorter, B.Sc.(Eng.), M.I.E.E.



for Head of Research Department

This Report is the property of the British Broadcasting Corporation and may not be reproduced in any form without the written permission of the Corporation.

This Report uses SI units in accordance with B.S. document PD 5686.

**PULSE-CODE MODULATION FOR HIGH-QUALITY SOUND-SIGNAL
DISTRIBUTION: APPRAISAL OF SYSTEM REQUIREMENTS**

Section	Title	Page
	SUMMARY	1
1.	INTRODUCTION	1
2.	PULSE-CODE MODULATION	2
	2.1. Basic Concept	2
	2.2. Quantizing Noise	3
	2.3. Compatibility with Existing P.C.M. Systems	5
	2.4. Practical Experience	5
	2.5. Idling Circuit Noise	6
3.	TECHNIQUES FOR IMPROVING THE SIGNAL-TO-QUANTIZING NOISE RATIO OF THE BASIC P.C.M. SYSTEM	6
4.	ALTERNATIVE METHODS OF DIGITAL CODING	10
5.	CONCLUSIONS	11
6.	REFERENCES	11
	APPENDIX	12

PULSE-CODE MODULATION FOR HIGH-QUALITY SOUND-SIGNAL DISTRIBUTION: APPRAISAL OF SYSTEM REQUIREMENTS

SUMMARY

For technical and economic reasons, the present network of lines used for distributing sound signals to transmitters at audio frequencies will eventually have to be replaced by some telecommunication system operating at frequencies above the audible range. For the immediate future, programme channels based on the existing carrier telephony network can be made available, but these are technically unsatisfactory for large-scale use, and for long-term development, a pulse-code modulation (p.c.m.) system is thought to offer a better solution.

This report, which is the first of a series, surveys the theoretical and operational considerations which enter into the design of a p.c.m. system for high-quality sound. Reference is made to the results of experimental work (details of which will be given in later reports) on the coding and decoding of the sound signals and on methods of incorporating a coded sound signal in the video signal.

1. INTRODUCTION

All major sound broadcasting organizations require an internal communication network for distributing programme signals between the various studio centres and the transmitting stations. Because of the similarity between sound programme signals and the speech signals of telephony, the networks used by broadcasting organizations are based on those used for telephony.

The existing BBC internal sound-distribution system employs "music lines", rented from the Post Office, in which the signals are carried at audio frequency within a bandwidth which rarely exceeds 10 kHz. Circuits of this type are becoming obsolescent because of the greater efficiency of wideband transmission networks such as coaxial cables and micro-wave links and it appears unlikely that any more music lines will be made available for broadcasting; when the music lines in use at present reach the end of their life, they will be withdrawn from service and not replaced.

In the immediate future the only alternative networks available for sound distribution are the "music-in-band" circuits which are based upon the

frequency-division-multiplex (f.d.m.) systems used for multi-channel carrier telephony in the existing wideband distribution networks; in a typical case the bandwidth occupied by three adjacent 4 kHz telephony channels provides one 12 kHz music circuit. Music-in-band circuits are not, however, wholly satisfactory for signals of broadcast quality, because the signal-to-(random) noise ratios obtainable, even with the use of pre- and de-emphasis, are generally marginal for a single circuit, and unacceptable when several such circuits are used in cascade. Syllabic companding has been tried in order to increase the signal-to-noise ratio, but this technique introduces other impairments and has not as yet been found to be acceptable for large-scale application. It would be unrealistic to expect any change in the standards of carrier telephony systems since the signal-to-noise ratios of these systems are adequate for the main purpose for which they were designed. It appears therefore, that in order to obtain a satisfactory distribution system using existing frequency-division-multiplex circuits, it would be necessary to use a more sophisticated method of carrier modulation by which an increase in signal-to-noise ratio is obtained at the expense of increasing the bandwidth; the resulting signal would inevitably occupy a greater number of telephony channels per programme.

The systems which make the most efficient use of wideband communication networks, and could in the future replace f.d.m., are those based on time-division-multiplex (t.d.m.) methods, in which each signal to be transmitted is represented by a sequence of pulses. For internal BBC use these systems can offer substantial advantages; they can be designed to give signal-to-noise ratios which are at least equal to, if not better than, those of equivalent frequency-division-multiplex systems; they can be substantially unaffected by system non-linearity and have very low crosstalk ratios between signals, the insertion and removal of a signal at intermediate points in a multi-channel link can be comparatively easy, and a sound signal of this type can be combined with a video signal during the line-blanking periods so as to permit the sound associated with a television programme to be transmitted over the links provided for the video signal.

Of the various forms of t.d.m., the best known examples of which are pulse-amplitude modulation (p.a.m.), pulse-position modulation (p.p.m.), pulse-duration modulation (p.d.m.), and pulse-code modulation (p.c.m.), the last-named is of special interest since it has already been chosen by the G.P.O. as the basis for future telephony network design¹. Although the application of pulse-code modulation to telephony has already been dealt with very fully in the literature^{2,3,4}, the special problems which arise in the use of this technique for the transmission of broadcast programme material have not received much attention. It was, therefore, decided, in the summer of 1966, to undertake a programme of work to determine whether p.c.m. can be used for this purpose in the immediate future and to specify the optimum parameters of a suitable system.

The present report, which is the first of a series, deals with the basic concepts of p.c.m. with special reference to high-quality sound-programme transmission. Some of the artifices which can be used to improve the basic system are described and a tentative description of the parameters of a possible system is given.

The second report of the series will describe an investigation into the possibility* of combining a p.c.m. signal with a video signal⁵ in the manner already indicated, while later reports^{6,7} will cover various other aspects of the work.

2. PULSE-CODE MODULATION

2.1. Basic Concept

Pulse-code modulation, like all time-division-multiplex systems, is based on the sampling theorems expounded by Nyquist and Shannon^{8,9}. These theorems may be summarized in a simplified form as follows: in order to transmit any waveform as a sequence of discrete amplitude-samples, it is necessary, and sufficient to send at least two samples per cycle of the highest frequency Fourier component of the waveform. For example, in order to transmit a sound signal which has a maximum frequency component of 15 kHz, it is necessary to sample at a rate somewhat greater than 30 kHz.

The signal which results from an amplitude sampling process is said to be pulse-amplitude modulated (p.a.m.) and it can be transmitted to the receiving terminal in any form thought desirable or convenient. At the receiving terminal the original waveform can be reconstructed from the p.a.m. signal by generating a $\sin x/x$ -shaped pulse proportional in amplitude to the sample pulse and having its zeros at those instants at which adjacent pulses have their maxima; the output signal is obtained by arithmetically summing these $\sin x/x$ pulses.

Fig. 1 shows in block diagram form a typical sampling arrangement as used in any time-division-multiplexing system. The input signal is band-limited by a low-pass filter to ensure that it is not possible to exceed the maximum frequency permitted by the sampling rate; the resulting signal is then sampled to produce a p.a.m. signal which is coded

* A proposal made independently by Mr. G.D. Monteath and one of the authors (DH).

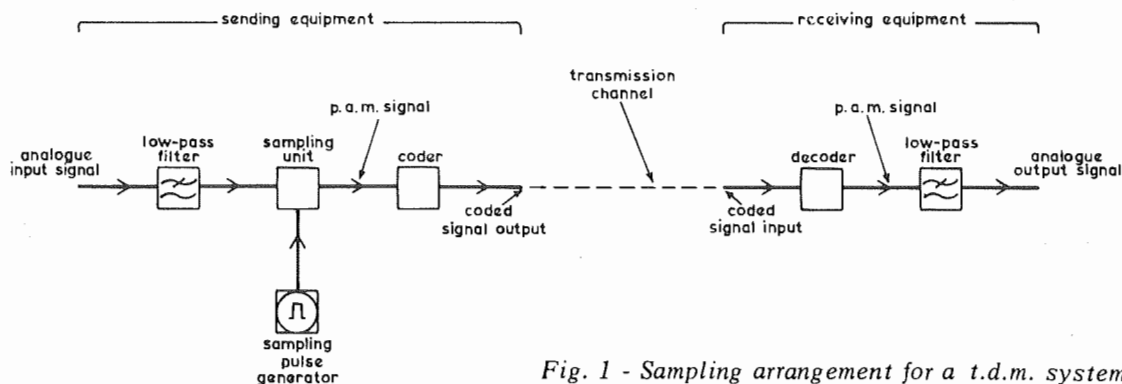

Fig. 1 - Sampling arrangement for a t.d.m. system

into the form chosen for transmission (p.p.m., p.d.m., p.c.m., etc.). At the receiving terminal the received signal is decoded into a p.a.m. form and the original waveform is reconstructed by means of a second low-pass filter, which in effect adds appropriate $\sin x/x$ pulses*. In practice it is necessary, in order to secure adequate attenuation of unwanted components, to make the cut-off frequency of the low-pass filters somewhat less than half the sampling frequency.

In pulse-code modulation, the magnitude of the sample is coded into a digital number which in turn is transmitted as a group of pulses. Each pulse may be made to assume one of a number of predetermined states - for example, the amplitude may have one of several discrete values or the polarity may be reversed - and means are provided at the receiving end of the system for distinguishing, without ambiguity, between one state and another. The number of alternative states which each pulse may assume is referred to as the base of the code.

One of the advantages of pulse-code modulation is that the form of coding used may be adapted to suit the characteristics of the communication channel over which the pulses are to be transmitted. The code is characterized by the number of pulses, n , corresponding to each signal sample and the number of states, m , which each pulse may assume. The communication channel, on the other hand, can be described, in essence, by its bandwidth and its signal-to-noise ratio. From the channel bandwidth can be deduced** the minimum spacing at which pulses can be transmitted and received without mutual interference, and thence, for a given sampling frequency, the maximum value of n . The signal-to-noise ratio sets an upper limit to the value of m , because the effect of noise is to introduce ambiguity in distinguishing between different states - for example, between different pulse amplitudes. The rate at which information is transmitted is proportional to m^n , and it is thus possible, by an appropriate combination of m and n , to make the most efficient use of the available channel bandwidth and signal-to-noise ratio by trading, in effect, the one quantity for the other. It should further be noted that pulse-coded signals can, if

* To obtain distortionless transmission of the waveform, both the input and the output low-pass filters must approximate to the ideal. For sound transmission, however, because of the relative insensitivity of the ear to moderate phase distortion¹⁰, it is permissible in practice to use conventional sharp-cut filters without group-delay correction although this does of course lead to some waveform distortion.

** With due allowance for the amplitude/frequency and phase/frequency characteristics of the system within the working band.

necessary, be transformed from one base to another at any point in the communication system by means of appropriate logic circuits, the rate of transmission of information remaining unchanged.

The most salient feature of pulse-code modulation is its extreme robustness in transmission. If the degree of pulse distortion or noise introduced in the full length of the communication channel is such as to prevent unambiguous detection of the coded signals, the latter can be detected and completely regenerated at one or more intermediate points; thus, the impairments produced by a p.c.m. system can be confined to those arising in the coding and decoding operation and do not increase with the distance over which the information is sent.

The commonest form of pulse-code modulation employs a binary code, i.e. m is equal to 2, the information being conveyed by the presence or absence of a pulse at a given instant of time. This type of coding is suitable for communication channels having a signal-to-noise ratio several orders of magnitude less than would be required for direct (i.e. analogue) transmission of the incoming signal, coupled with a bandwidth sufficient to compensate, in terms of information-carrying capacity, for this deficiency; moreover, since the decoding process is not critically dependent on the amplitude of the received pulses, non-linear distortion in the channel has little or no effect.

The binary-coded p.c.m. system, which was invented in 1937¹¹, has been exhaustively treated in the literature and only a brief resumé of its salient features will be given here. Because of the potential application of such a system to BBC requirements, the remainder of this section is written in terms of a binary-coded signal; much of this material, however, applies equally to transmission by codes having bases other than 2.

Fig. 2 illustrates the process of coding and decoding in a four-digit binary p.c.m. system, in which the instantaneous signal level is represented by any one of 16 different codes. The significance of this latter process is discussed in the next section.

2.2. Quantizing Noise

The principal disadvantage of p.c.m. is caused by the fact that, as the amplitude of each sample is described by a digital number, the data to be transmitted must be represented by a set of discrete amplitudes; the output obtained from a p.c.m. system is therefore quantized into discrete levels, the number of which is determined by the

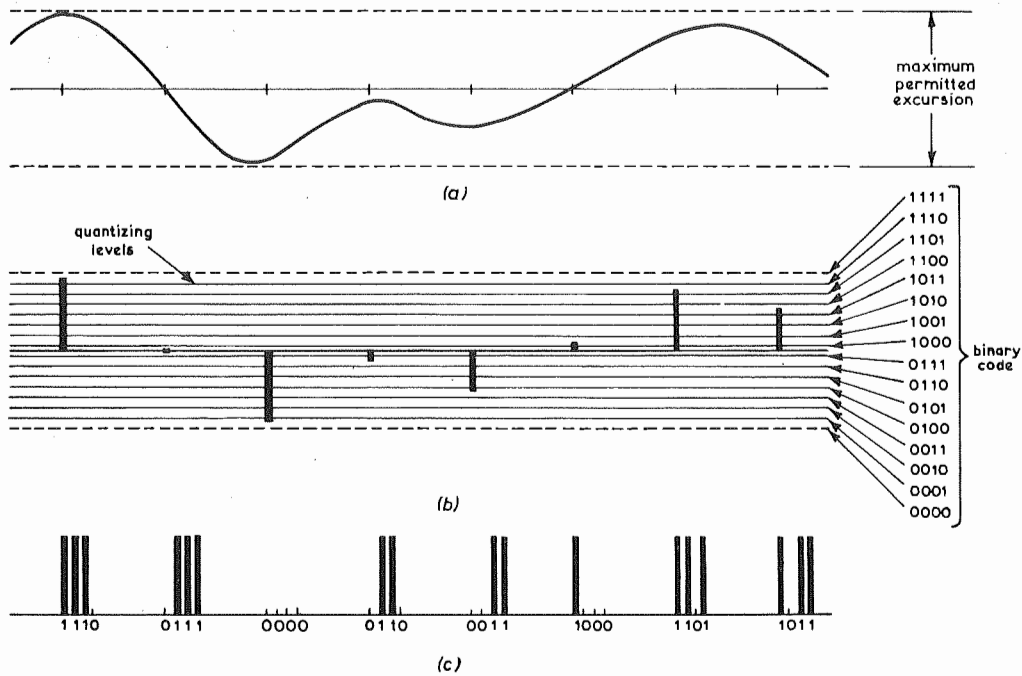

Fig. 2 - Binary p.c.m. coding for a 4-bit system

- (a) Band-limited analogue signal
 (b) Pulse amplitude modulated signal derived from (a); the binary code used to represent the quantizing levels is shown on the right.
 (c) Binary pulse-code modulated signal derived from (b)

number of digits per sample. The output signal can thus be regarded as a perfect representation of the input signal together with an error caused by the quantizing. It is self-evident that the magnitude of this error lies within the range of plus and minus half of one quantizing step, but its subjective effect is not so obvious. The audible effect of the error produced by quantizing closely resembles that of random (white) noise provided that the number of quantizing levels covered by the signal is not too small⁴; for this reason the error is always referred to as "quantizing noise" (q.-noise). The

calculated values of the signal-to-q-noise ratios for 10, 11 and 12-digit p.c.m. systems are shown in Table 1 in the three forms most commonly used; the derivation of these figures is given in the Appendix. These theoretical figures may be difficult to attain in practice because of the high order of instrumental accuracy required. This point is illustrated by the figures in the last column of Table 1 which show the limits within which the amplitude of a given sample must be measured and then reconstructed from the digital number if the least significant digit is to be effective.

TABLE 1

The signal-to-quantizing noise ratios of binary p.c.m. systems

number of bits	$\frac{\text{peak-to-peak signal}}{\text{peak-to-peak q.-noise}}$	$\frac{\text{peak-to-peak signal}}{\text{r.m.s. q.-noise}}$	$\frac{\text{peak signal}}{\text{peak weighted noise (PPM)}}$	Instrumental accuracy required
10	60	71	53	0.1%
11	66	77	59	0.05%
12	72	83	65	0.025%

The acceptance limit for the ratio of peak signal-to-peak weighted noise for a music line is at present 60 dB and the rejection limit 55 dB. Applying this figure to quantizing noise, it can be seen, from Table 1, that a system using 10 binary digits (bits) per sample would be unsatisfactory, 11 bits per sample would be on the threshold of acceptability while a 12 bit/sample system would be quite acceptable.

It should be emphasized that noise added to the coded signals in course of transmission, unless of sufficient magnitude to cause errors in decoding, has no effect on the output signal. It can be shown³ from statistical considerations that with random noise having an r.m.s. value only 23 dB below the bit-pulse amplitude, the rate of error amounts to one pulse in 10^{12} , which can probably be regarded as negligible.

The quantizing noise at the output of a p.c.m. system will be increased if the signal is repeatedly decoded and recoded; the increase in noise level will be 3 dB for one additional decoding and recoding operation, 4.8 dB for two such operations, 6 dB for three, and so on. However, there is no fundamental reason why a signal need be coded and decoded more than once; the extraction of one or more out of a number of programmes carried by a "bit stream" is a simple operation as is also its insertion. The mixing of signals representing programme contributions from several sources can be effected by the use of digital techniques similar to those employed in computers.

2.3. Compatibility with Existing P.C.M. Systems

The transmission channels likely to be used for programme distribution by p.c.m. have an information capacity greatly in excess of programme requirements and for efficient utilization must be shared by a number of services. It is therefore desirable that the standards adopted for programme distribution should be compatible with those adopted by the Post Office; even if the BBC were to operate a separate distribution network, it would be advantageous to be able to employ commercial equipment of the type developed for Post Office use.

The circuits envisaged by the Post Office¹² are based on a sampling rate of 8 kHz, 8 bits per sample ($m = 2$, $n = 8$) and 24 channels per circuit; the bit rate for a standard Post Office circuit will therefore be 1536 k bits/sec ($8k \times 8 \times 24$). It has already been stated that a sampling rate in excess of 30 kHz is necessary for signals of broadcast quality, which suggests that a convenient choice of parameters for the efficient use of a standard circuit might be based, for example, on four mono-

phonic or two stereophonic programmes, utilizing a sampling rate of 32 kHz, each sample consisting of 12 bits. In this case, however, the coded samples would occupy the entire channel capacity leaving no room for synchronizing signals; it would then be necessary to use sophisticated statistical methods to decode the received signals correctly.¹³ In a practical coding system it is usual to send the digit pulses representing one sample from each of the channels sequentially, and a block of pulses which represents a total of one sample from every channel is known as a frame. In order to decode the signals it is necessary to determine which of the pulses in the sequence is the first in the frame and adjust the logic circuits of the decoder accordingly, a process known as framing.* For this reason it would be preferable in the case under consideration, to restrict the number of bits per sample to 11, thus leaving 4 bits per frame, i.e. 128k bits/sec ($4 \times 32k$ bits/sec), for other purposes. For framing purposes 32k bits/sec would be sufficient, leaving 96k bits/sec which could be used for a telephony channel (64k bits/sec) plus monitoring or teleprinter facilities (32k bits/sec).

The above calculation does not take into account the possibility that, in order to conform with existing p.c.m. transmission systems, it may, in practice, be necessary to place some restriction on the codes that may be used - for example, by excluding certain combinations of digits or by introducing redundancy¹⁴. In these circumstances, it may be that the whole of the information capacity of a 1536k bits/sec channel will be required for the transmission of four 11-digit programme signals.

2.4. Practical Experience

In view of the foregoing considerations, it was decided as a feasibility study, to construct in the laboratory a p.c.m. system⁶ to the following specification:

* At the sending end of the system, successive frame pulses are switched on or off according to a predetermined time pattern - for example, it may be arranged that every other pulse is absent. At the receiving end, an identical time pattern is generated, and compared, over a suitable time interval, with the pattern of received pulses appearing in a series of "time slots" one frame-interval apart. If the system is out of synchronization, the time slots which should contain the framing-pulse pattern will be occupied instead by some fortuitous sequence derived from the signal pulses; the probability that this latter sequence will be the same as the framing-pulse pattern and remain so while the comparison is being made is extremely small, and can be reduced to negligible proportions by increasing the number of time slots to be compared. Correction for the out-of-synchronization condition is made by causing the decoder timing to slip by one digit at a time until the prescribed framing-pulse pattern emerges.

Sampling frequency	: 32 kHz
Bits per sample	: 11
Upper a.f. limit	: 14 kHz
Lower a.f. limit	: determined by associated a.f. terminal equipment

Experience gained with this equipment operating with the coder directly connected to the decoder showed that a signal-to-noise ratio within 4 dB of the theoretical figure (see Table 1) can be obtained. Although this figure just falls below the rejection limit, there are techniques which can be used to improve the signal-to-noise ratio of a simple p.c.m. system; by the implementation of these techniques, which are described in a later section, it seems likely that an acceptable system based on 11 digits per sample could be achieved.*

2.5. Idling Circuit Noise

During quiescent periods of a programme, the output obtained from a p.c.m. system depends upon the standing voltage applied to the analogue to digital converter (a.d.c.) of the coder, and upon any noise - including interference such as hum - which happens to be present at the coder input. If the input circuit is so arranged that the standing voltage lies somewhere between two "decision" levels, the coded output will be constant from sample to sample, and the decoded output will be zero, provided that the noise voltage is insufficient to cause any decision levels to be crossed. If, however, noise of sufficient magnitude to cross decision levels is present, changes in code will be produced which will cause randomly-occurring voltage steps to appear at the receiving end of the system; the resulting output is known as "idling circuit noise."

The worst condition arises when the fluctuating noise voltage is so small that only the highest values attained can reach a decision level; in these circumstances the idling circuit noise heard at the output of the system has an intermittent spiky character which is more objectionable to the ear than is the characteristic hiss of the quantizing noise accompanying a normal signal. The effect is particularly noticeable when speech from a non-reverberant environment is being transmitted; the transition from hiss to spiky noise can then be heard between words. A preferable condition of operation can be obtained by ensuring that decision levels are crossed more frequently, in which case

* It has been found by experiment (see Ref. 5) that for the transmission of combined video and p.c.m. sound signals over existing video distribution networks, the optimum number of bits per sample is also 11.

the idling circuit noise can be made to sound like quantizing noise. One possible method of achieving this would be to maintain the standing voltage of the input circuit exactly at a decision level. An alternative solution which has been suggested is to add, to the incoming signal, an agitating voltage of suitable waveform to ensure that the system is never idle. This agitating waveform could take the form of a single frequency a little higher than the maximum to be transmitted, or a signal within the audio-frequency band, which is subsequently removed from the output by cancellation, or by a filtering technique.

3. TECHNIQUES FOR IMPROVING THE SIGNAL-TO-QUANTIZING NOISE RATIO OF THE BASIC P.C.M. SYSTEM

Many techniques for improving the signal-to-quantizing noise ratio of the basic p.c.m. system have been proposed; some of these are closely allied to the methods used to improve the signal-to-random noise ratio of analogue systems, whilst others take advantage of the digital nature of the p.c.m. system. The aim of many of these techniques is to reduce the number of bits per sample used, often by taking advantage of the redundancy in the signal or by limiting the form which the signal is permitted to assume. For high-quality sound-signal transmission, it is considered not worthwhile to try to reduce the number of bits per sample or, at the present time, to try to exploit redundancy in the signal; further, limiting the form which the sound signal is permitted to assume is, in general, unacceptable. Of the methods known to the authors, only those which seem to be applicable to the transmission of high-quality sound will be described in this report.

(a) Pre-emphasis and De-emphasis

A simple method of improving the signal-to-noise ratio of a communications system uses pre- and de-emphasis of the higher signal frequencies. The principle of operation of this method is well known. The noise is reduced by attenuating its high-frequency Fourier components at the output by means of a "de-emphasis" network; inevitably, the high-frequency components of the signal are also attenuated and the signals must therefore be pre-corrected before transmission by means of a pre-emphasis network so as to re-establish the original relationship between the amplitudes of the high- and low-frequency components.

This method of improving the signal-to-noise ratio depends upon the assumption that the high-frequency components of the signal

are smaller in amplitude than those of low frequency, and the characteristics of the pre-emphasis network must be chosen with care to ensure that the high-frequency components are not so far increased in amplitude as to cause overloading of the system. Even so, for some types of programme, such as an orchestral passage containing vigorous cymbal clashing, the peak value of the pre-emphasized signal may exceed the overload point of the system; this difficulty might well be overcome by momentarily reducing the level or momentarily removing the pre- and de-emphasis by means of some automatic control device.

Pre-emphasis and de-emphasis networks for use on music-in-band circuits have been recommended by the CCITT; Fig. 3 shows the attenuation/frequency characteristic of the pre-emphasis network. The improvement in signal-to-noise ratio obtained from the inclusion of such networks lies between 3 dB and 7.5 dB¹⁵ according to the allowance made in the setting-up procedure to avoid the occasional overloading at high audio frequencies, referred to above.

The pre- and de-emphasis method using the CCITT networks is directly applicable to p.c.m. systems. Because the p.c.m. system can produce only a restricted range of digital numbers it has a well defined overload point and it is in any case essential to include a fast-acting a.g.c. device to control the input signal level. If this device is inserted after the pre-emphasis network it will ensure that the pre-emphasis of the high frequencies does not cause overloading and it should therefore be possible to set up the system so as to achieve the maximum improvement in signal-to-quantizing noise ratio for most of the time.

An experiment carried out to confirm this conclusion, using an analogue system with a recently developed experimental limiter¹⁶ as

the control device, showed that, with the system set up to obtain a 7.5 dB improvement in signal-to-noise ratio, overloading did not occur; however, for an orchestral programme of the type described above there was a perceptible reduction in gain during the forte passages which considerably spoiled the enjoyment of the piece*.

The conclusion drawn from this experiment was that a system including the CCITT pre- and de-emphasis networks together with a control device would have to be set up at a level about 4 dB lower than normal, so that the improvement in signal-to-noise ratio obtained would be only 3.5 dB. For a practical 11-bit p.c.m. system of the type described previously, therefore, the addition of CCITT pre- and de-emphasis networks and a suitable control device should result in a signal-to-noise ratio of about 58 dB if allowance is made for imperfections in instrumentation (see Section 2.4). It is doubtful whether this figure is quite acceptable for the highest grade of service.

(b) Companding

It is usual to specify the noise level in a sound transmission channel with reference to the maximum signal level that the channel will transmit without distortion: the level of noise that is permissible, however, is determined by its subjective effect when the signal level is low. It is therefore possible to increase the effective signal-to-noise ratio for a given channel by the use of an automatic gain control at the input of the system to bring the signal

* This condition could be avoided if channel capacity could be made available for the transmission of a pilot signal indicating the amount of gain reduction caused by the limiter, which could then be compensated at the receiving end of the system; however, this would lead to further complications in the coding and decoding equipment.

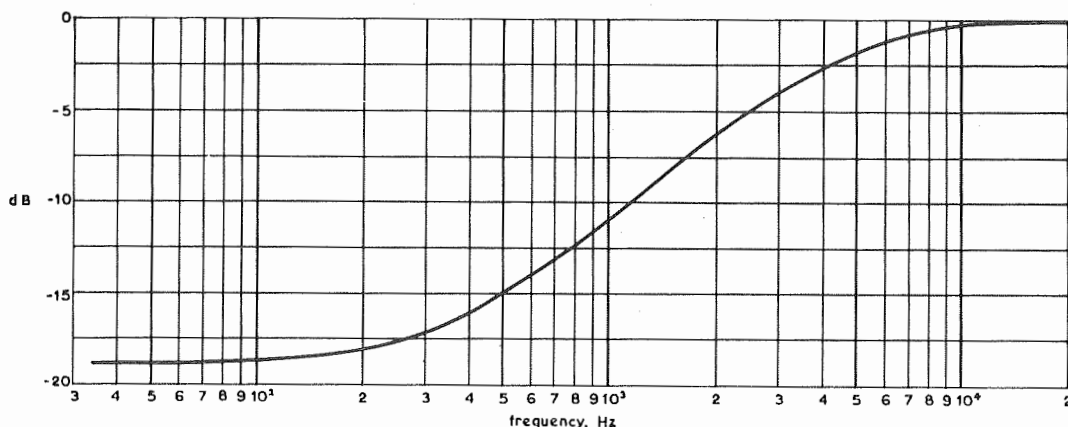

Fig. 3 - CCITT pre-emphasis characteristic

level nearer to the permitted maximum; at the receiving terminal, compensating gain changes are introduced by a second automatic gain control having characteristics complementary to those of the first. The automatic gain control at the sending end of the system reduces the amplitude range of the signals applied to it and is therefore known as a compressor; the complementary device at the receiving end of the system is referred to as an expander and the two together as a compandor.

The variation of gain in the compressor modulates the signal, producing additional frequency components; for distortionless transmission, these extra components must arrive together with the original signal components at the receiving terminal without amplitude or phase distortion, and must then be cancelled in the process of expansion.

In analogue transmission this requirement is met by syllabic compandors, in which the rate-of-change of gain is so slow that the additional components are confined to the frequency range which can be transmitted without serious distortion. In p.c.m. transmission, on the other hand, no such restriction is necessary provided that all additional frequency components generated by the compressor are transmitted unimpaired to the a.d.c. and, at the receiving terminal, from the digital to analogue converter (d.a.c.) to the expander; there is no great difficulty in providing adequate bandwidth in the circuits concerned, and it is thus possible to employ other methods of signal processing which operate instantaneously.

Instantaneous companding networks used in p.c.m. telephony circuits make use of the non-linear characteristics of diodes. To avoid waveform distortion of the received signal, the characteristics of the compressor and expander must be exactly complementary. This requirement can be sufficiently well met for telephony circuits; for high-quality programme circuits, on the other hand, the standards required are much more exacting and it has been found⁷ extremely difficult to reduce the audible distortion to tolerable proportions and to maintain this standard of quality over long periods. For this reason, instantaneous companding by operating on the analogue signal is considered unsuitable for the present purpose.

Since the gain of the expander increases with signal level, it follows that any noise originating in the transmission system between compressor and expander becomes modulated in accordance with the programme level. In

telephony systems, this fluctuating noise - commonly referred to onomatopoeically as "hush-hush-noise" - is to a large extent masked by the signal itself and even when audible can be tolerated as long as intelligibility is not impaired. However, in wide-band sound systems for the transmission of broadcast programmes, the predominant components of the signal and of the noise often lie too far apart in the a.f. spectrum for masking to be effective; moreover, even a small amount of programme-modulated noise can be aesthetically objectionable, producing a sound akin to that associated with high-order harmonic distortion.

The subjective effects of programme-modulated noise can be mitigated by dividing the audio-frequency band into several channels by appropriate filters, each band being provided with an independent compressor and expander; the outputs from the individual compressors are combined at the sending end of the system and split between the corresponding expanders at the receiving end. Any noise components appearing in a frequency band containing little or no signal energy are thus subject to the maximum attenuation in the expander. The practical realization of such devices, however, entails considerable instrumental complication, and stringent requirements have to be imposed on the filters if the overall response/frequency characteristic of the system is to be maintained independent of signal level.

The total amount of programme-modulated noise energy appearing at the output of a compandor depends on the operating time of the variable-gain devices; this consideration applies particularly to the time interval which elapses between a reduction in signal level and the corresponding reduction in expander gain - and hence in noise output. In this respect, an instantaneous compandor has an advantage over a syllabic compandor; the difference in subjective assessment of the fluctuating noise in the two processes may, however, be partly offset by an increase in annoyance value with the rate of fluctuation.

A further factor which influences the effect of programme-modulated noise in compandors is the output/input characteristic of the compressor since this determines the relationship between signal level and noise at the output of the system. If the output/input characteristic of the compressor is of the form indicated by curve (a) in Fig. 4, all incoming signals at levels above some low value P_1 will be subject to gain reduction and their level

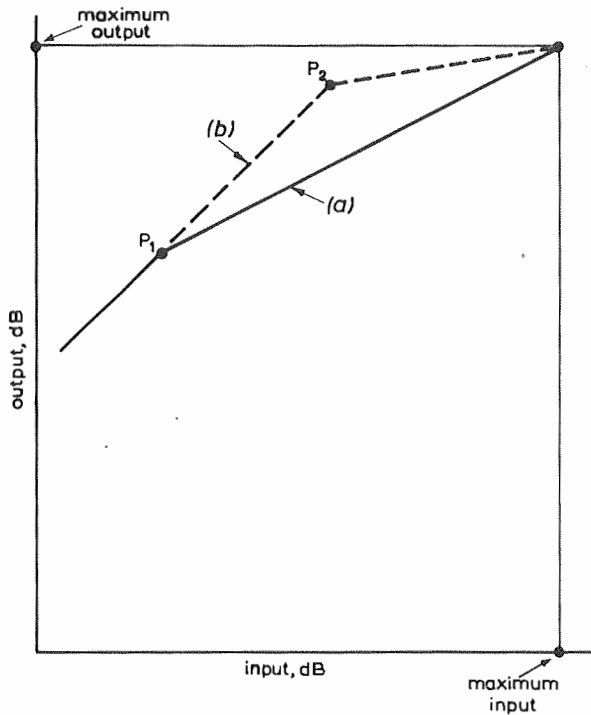

Fig. 4 - Alternative output/input characteristics of compressor

fluctuations will produce corresponding fluctuations in noise at the output of the expander. If, on the other hand, the gain reduction occurs only at signal levels above some point P_2 near to the permitted maximum output for the transmission system as indicated by curve (b), the resulting noise, while more sudden in its onset, will occur only during the loudest passages in the programme, and may then be masked. As far as is known, no formal investi-

gation has been carried out to find the optimum form of compression characteristic from this point of view, and current practice is dictated rather by instrumental considerations.

Alternative methods of companding can be developed by taking advantage of the nature of the p.c.m. system. One method would be to operate the a.d.c. and d.a.c. using complementary non-linear codes. In this way the quantizing levels could be made to be closer together at low signal levels, thus reducing the quantizing noise, and wider spaced at high signal levels, giving an increase in quantizing noise. The subjective effect of this redistribution would be identical with that obtained from a perfect analogue-signal compandor of the type previously described.

(c) Automatic Ranging Coding

Another method of signal processing which is thought to be preferable to that of non-linear coding takes advantage of the digital nature of the coded signal.¹⁷ Fig. 5 shows a block diagram of such a system, in which two of the eleven digits are used to transmit a scale factor to indicate which of four voltage ranges the sample occupies. This factor is used to control the input to the nine-digit a.d.c. so that the p.a.m. level is maintained as high as possible without exceeding that which can be represented by the digital number. The coded output consists of the two-digit scale factor

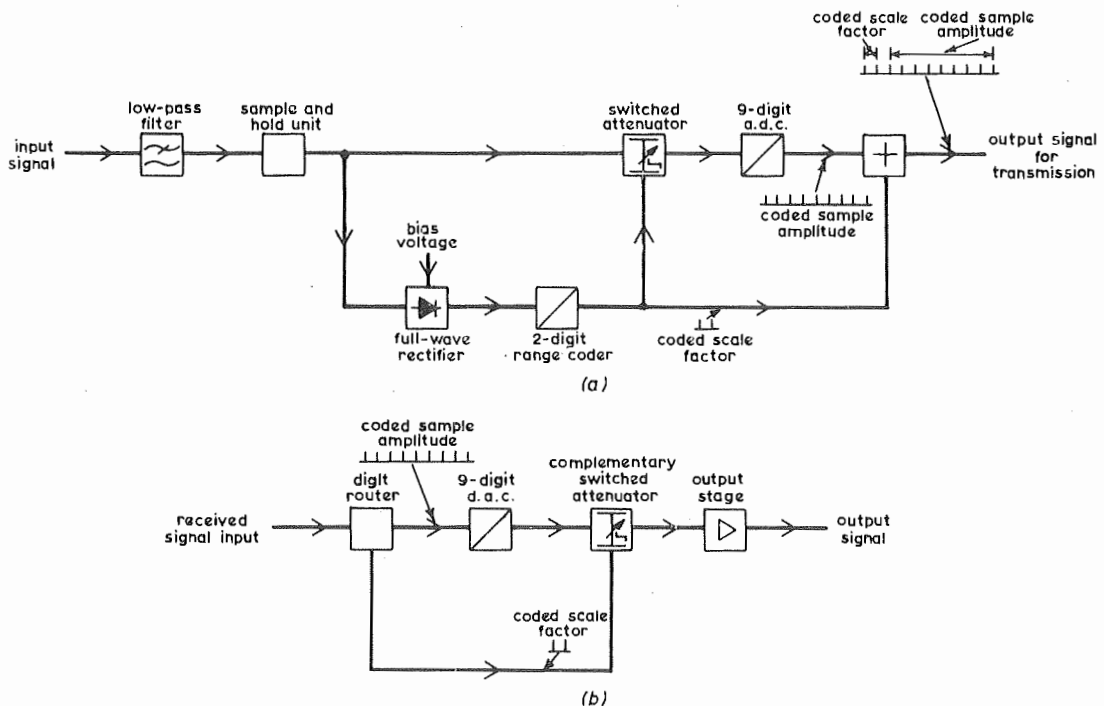

Fig. 5 - Coding and decoding system employing automatic ranging

(a) P.C.M. sending terminal equipment (b) P.C.M. receiving terminal equipment

and the nine-digit sample number sent in sequence. At the receiving terminal the nine-digit sample number is decoded by means of a d.a.c. whilst the two-digit scale factor is used to adjust an attenuator after the d.a.c. so that the signal obtained at the output is of the correct magnitude.

The process of assigning a scale factor to each signal sample is analogous to the action of a digital voltmeter provided with automatic ranging; the principle outlined above will therefore be referred to for brevity as automatic ranging coding (a.r.c.).

The advantages of the a.r.c. system are that it is simple to instrument and rigorous in operation, because the same control number is used in both the a.d.c. and the d.a.c. It is thought that this technique could make the signal-to-q-noise ratio of a system employing a total of eleven digits per sample acceptable for service, though it remains to be seen whether any unacceptable side-effects would be introduced.

The concept of using control digits is a powerful one and there are many ways in which it can be used to improve the transmission characteristics of the basic p.c.m. system.

(d) Noise Reduction by Delayed Feedback

Many methods have been devised of reducing the quantizing noise by taking advantage of the special characteristics of t.d.m. signals. Of these, one system, proposed by Cutler^{18,19}, is particularly interesting for the case of p.c.m. In the system in its simplest form, a voltage equal to the error in the p.a.m. signal at the receiving terminal is generated at the sending terminal, by decoding the p.c.m. signal output and subtracting the resulting quantized p.a.m. samples from the p.a.m. samples derived from the incoming signal. The difference, representing the error from any particular sample, is added to the succeeding sample. If, then, the p.c.m. signal sent to line represents too small a value, the error will be positive and the following sample will be increased in amplitude. This action increases the probability that the next decoded sample will be too large and give a negative error; however, a negative error, when added to a sample, reduces its size and increases the probability that the next error will be positive. It will be seen that this method is in effect a type of feedback into which "controlled hunting" has been introduced. It can be shown that the effect of this hunting is to transfer energy from the low-

frequency q-noise components to the high. By a judicious choice of band-limiting filters and sampling rate much of the high-frequency noise components can then be removed without serious impairment of the signal.

This artifice can be made more effective by feeding back not only the error from the sample which immediately preceded the one being fed into the coder but also information from earlier samples.

4. ALTERNATIVE METHODS OF DIGITAL CODING

Pulse-code modulation is, in concept, the simplest system for the transmission of analogue signals in digital form. However, it is considered by some authorities to be a wasteful system in that it does not exploit the redundancy thought to occur in many signals; moreover, it requires complex instrumentation. Many alternative systems of coding which make use of simpler terminal equipment and which exploit redundancy have been proposed; the chief amongst them is delta-modulation.

There are many varieties of delta-modulation. In the original proposal²⁰ the signal was sampled at a high rate and adjacent samples compared in amplitude. If the comparison showed the signal amplitude to have increased by more than a certain amount, a "one" digit pulse was sent; if the comparison showed no such increase, a "zero" digit pulse was sent. The principal advantage claimed for this system was its instrumental simplicity; for example, the circuit required to decode the received signal was a simple passive integrating network.

The simple delta-modulation system originally proposed has undergone many modifications to improve its performance²¹ and more variants of it are still being invented.^{22,23} The one most likely to find application in the transmission of high-quality sound signals is also that which is closest to p.c.m. In this variant the difference in amplitude between successive samples is transmitted as a digital number and for this reason it is often termed "differential p.c.m."* If it must be assumed that sounds occur in nature which require successive samples to have amplitudes at opposite extremities of the range, then the number of digits required to transmit the signal is identical to the number required for p.c.m. and nothing is gained by the use of delta-modulation (a little may be lost because the instrumentation will be slightly more complex).

* There is some confusion between the terms applied to delta-modulation by different authors.

If, however, it can be proved that changes in amplitude of greater than 50% of the maximum signal amplitude cannot occur between adjacent samples, a delta-modulation system could lead to either the saving of one digit in a binary system or alternatively an improved signal-to-q-noise ratio.

As yet delta-modulation systems have not been used for commercial telephony applications, and it seems that a considerable amount of work might be required to determine whether a system for high-quality sound signals would be worthwhile. In view of this it was decided to pursue the study of delta-modulation theoretically but not to commence any practical experiments at the present time. If as a result of future improvements in technology, coupled with a better understanding of the nature of the sound signal to be transmitted, some variant of delta-modulation is shown to be preferable to p.c.m., only the terminal equipment will need to be modified, since transmission channels suitable for multiplexed p.c.m. systems are suitable for multiplexed delta-modulation systems, or even a mixture of the two.

5. CONCLUSIONS

From a survey of known art, it is concluded that pulse-code modulation should be capable of satisfying present and foreseeable future requirements for a high-quality sound-signal distribution network.

Experimental coding and decoding equipment has been constructed to the specification given in Section 2.4. The results showed that it is possible to engineer an 11-digit system having a performance close to that predicted by theory; from the experience obtained, it is concluded that an efficient 12-digit system is practicable. Whilst a 12-digit system would be preferable, 11 digits would fit more readily into the standards adopted by the Post Office. With the lower number of digits, the signal-to-q-noise ratio falls somewhat short of requirements and some form of noise-reducing technique will therefore be necessary. A small improvement in signal-to-noise ratio is obtainable by the use of pre- and de-emphasis; alternatively or in addition, some other form of signal processing could be used. Analogue companders, whether syllabic or instantaneous, of the type hitherto used in telephony, are unsatisfactory for high-quality sound systems but, with a p.c.m. system, alternative techniques, such as automatic ranging coding, utilizing one or more of the transmitted digits for control purposes, can be employed.

A system operating on the lines indicated in this report is capable of transmitting a somewhat

wider audio-frequency bandwidth than is at present provided for transmitters outside the London area, with a signal-to-noise ratio conforming to existing tolerances. The standard of performance attained is not degraded by regeneration at repeater stations, while monitoring of the links is reduced to the simple process of verifying the presence of the pulse signals.

6. REFERENCES

1. Electron Aspects - G.P.O. orders p.c.m. equipment. *Electron. & Pwr.* 1966, 12, September, p.309.
2. OLIVER, B.M., PIERCE, J.R. and SHANNON, C.E. 1948. The philosophy of p.c.m., *Proc. Inst. Radio Engrs.*, 1948, 36, 11, pp. 1324-1331.
3. Bell Telephone Laboratories: Technical Staff. 1965. Transmission systems for communications. Winston-Salem, Bell Telephone Laboratories, Inc., 1965. Chapters 24 and 25.
4. PANTER, P.F. Modulation, noise and spectral analysis. New York, McGraw-hill, 1965. Chapter 20.
5. Pulse-code modulation for high-quality sound-signal distribution: incorporation of the sound signal in the video signal. BBC Research Department report in course of preparation.
6. Pulse-code modulation for high-quality sound-signal distribution: coding and decoding. BBC Research Department report in course of preparation.
7. Pulse-code modulation for high-quality sound-signal distribution: instantaneous companders using diodes as non-linear elements. BBC Research Department report in course of preparation.
8. NYQUIST, H. 1928. Certain topics in telegraph transmission theory. *Trans. Am. Inst. elect. Engrs.*, 1928, April, pp. 617-644.
9. SHANNON, C.E., 1948. Communication in the presence of noise. *Proc. Inst. Radio Engrs.* 1949, 37, 1, pp. 10-21.
10. BELGER, E., PAVEL, E.A. and RINDFLEISCH, H. 1955. Über den Einfluss von Laufzeitverzerrungen und Frequenzbandbesneidungen bei der Übertragung von Rundfunkdarbietungen, *Fernmeldetech. Z.*, 1955, 8, 8, pp. 445-455.

11. The father of p.c.m., an interview with A.H. Reeves. *Electron. & Pwr.* 1964, **10**, October, pp. 344-346.
12. Development of pulse-code modulation systems. *P.O. elect. Engrs' J.*, 1966, **59**, 1, pp. 10-11.
13. SALTZBERG, B.R. 1966. Timing recovery for synchronous binary data transmission. *Bell Syst. tech. J.*, 1967, **66**, 3, pp. 593-622.
14. CATTERMOLE, K.W. 1967. Low-disparity codes and coding for p.c.m. *Symposium on Transmission Aspects of Communications Networks*. London, I.E.E., 1964, pp. 179-182.
15. Pre-emphasis on S.B. Lines; CCITT Recommendations. BBC Designs Department Technical Memorandum No. 2.149(64).
16. The dynamic characteristics of limiters for sound programme circuits. BBC Research Department Report No. EL-5, Serial No. 1967/13.
17. BARTLETT, C.J.C. and GRESZCZUK, J., 1964, Companding in a p.c.m. system. *Symposium on Transmission Aspects of Communications Networks*. London, I.E.E., 1964, pp. 183-186.
18. CUTLER, C.C. Transmission systems employing quantization. U.S. Patent No. 2,927,962; 1960.
19. SPANG, M.A. and SCHULTHEISS, P.M. 1962. Reduction of quantizing noise by use of feedback, *I.R.E. Trans. Commun. Syst.*, 1962, **CS10**, 4, pp. 373-380.
20. JAGER, F. de, 1952. Delta modulation - a method of p.c.m. transmission using the 1-unit code. Jackson, W. ed. 1952. *Communication Theory; papers read at a Symposium on "Applications of Communication Theory"*. London, Butterworths, 1953, pp. 119-137.
21. PANTER, P.F. 1965. Modulation, noise and spectral analysis. New York, McGraw-Hill, 1965, Chapter 22.
22. ABATE, J.E. 1967. Linear and adapting delta modulation. *Proc. IEEE*, 1967, **55**, 3, pp. 298-308.
23. BELLO, P.A., LINCOLN, R.N. and GISH, H. 1967. Statistical delta modulation. *Proc. IEEE*, 1967, **55**, 3, pp. 308-319.

APPENDIX

The Specification of Signal-to-Noise Ratios with Particular Reference to Sound Circuits

The signal-to-noise ratios of circuits used in different branches of communications engineering are specified in a number of different ways. In p.c.m. systems for sound transmissions, three of the different branches are brought together, and confusion can arise when stating signal-to-noise ratios if the exact terms of measurements are not made clear. The purpose of this Appendix is to state explicitly the relationship between the methods of specifying signal-to-noise ratio most applicable to p.c.m.

The simplest method of expressing the signal-to-quantizing noise ratio of a p.c.m. system is in terms of the peak-to-peak signal to peak-to-peak noise, because the former quantity is the sum of the heights of all the quantizing steps covered by the signal while the latter is equal to the height of one such step. Hence for a binary p.c.m. system using "n" digits, giving 2^n quantizing steps, all assumed to be of equal height,

$$20 \log_{10} \frac{\text{peak-to-peak signal}}{\text{peak-to-peak q-noise}} = 20 \log_{10} 2^n = 6n \text{ dB} \quad (1)$$

In many branches of communications engineering, for example, the transmission of television signals, it is more usual to express the signal-to-noise ratio in terms of peak-to-peak signal and r.m.s. noise. The magnitudes of the random errors which form the quantizing noise have a rectangular probability density function, whence it can be shown by relatively simple statistical methods that the ratio of peak-to-peak to r.m.s. values is $2\sqrt{3}$ which is equivalent to 10.8 dB.²³ Hence in these terms, for a binary system using "n" digits

$$20 \log_{10} \frac{\text{peak-to-peak signal}}{\text{r.m.s. q-noise}} = (6n + 10.8) \text{ dB} \quad (2)$$

In systems for the transmission of broadcast sound programmes, it is common practice to define the signal-to-noise ratio in terms of the r.m.s. value of a sinusoidal signal, which is 9 dB less than its peak-to-peak value; the signal-to-noise ratio expressed in these terms is therefore

$$20 \log_{10} \frac{\text{r.m.s. signal}}{\text{r.m.s. q-noise}} = (6n + 1.8) \text{ dB} \quad (3)$$

If now it be assumed that quantizing noise,

despite its different statistical distribution, is subjectively equivalent to "white" gaussian noise (constant power per Hz of bandwidth) having the same power and the same frequency range⁴, the figures given in (3) can be directly compared with signal-to-noise ratio data for any other transmission system in which the noise is of the white gaussian type.

For transmission systems having noises of widely differing character, it is not possible to compare the degree of subjective disturbance by considering the total noise power in each case, and in an attempt to overcome this difficulty, special methods of measuring and specifying signal-to-noise ratios have been adopted. Quantizing noise cannot in any case be measured directly, since it exists only in the presence of a signal; the relationship given in (3) can, however, be adapted for various methods of measurement by substituting the equivalent white gaussian noise (abbreviated e.w.g-noise), to which the appropriate conversion factors may then be applied.

It is a common practice to weight the different Fourier components of the noise to be measured, in accordance with an aural sensitivity characteristic standardized by the CCITT. This weighting, applied to white gaussian noise extending over the audio-frequency range up to 15 kHz, raises the r.m.s. value by 4.2 dB. Thus from (3)

$$20 \log_{10} \frac{\text{r.m.s. signal}}{\text{r.m.s. weighted e.w.g-noise}} = (6n - 2.4) \text{ dB} \quad (4)$$

Because of the difficulty of assessing, with an r.m.s. meter, the impulsive type of interference

produced, for example, by switching induction, it has long been the practice of the BBC to substitute for the r.m.s. meter, for the purpose of noise measurement, the Peak Programme Meter already used to measure programme levels. This instrument, although calibrated in terms of the r.m.s. value of a sinusoidal signal, is of the quasi-peak indicating type and its readings are therefore referred to in operational terminology as "peak". The PPM reading obtained with noise is a function of the time constants of the rectifier system; for white gaussian noise after CCITT weighting, it has been established empirically as 5 dB higher than the reading produced on an r.m.s. meter that has been adjusted to give the same reading of a sinusoidal signal as would be given by a PPM. This conversion, applied to (4) gives

$$20 \log_{10} \frac{\text{peak signal}}{\text{peak weighted e.w.g-noise}} = (6n - 7) \text{ dB to the nearest decibel,} \quad (5)$$

for the signal-to-noise ratio as read on a PPM.

Finally, it should be noted that, for operational reasons, it is customary to specify the signal power in a programme circuit by relating it to the level of the test tone used to line up the system. Unfortunately, there is a disparity between U.K. and continental practice in this matter. In the terminology of the CCITT and EBU, the maximum permitted signal level is 9 dB above the level of the "line-up" of test tone, while in BBC practice, the maximum signal is restricted to 8 dB above line-up level. This means that, other things being equal, a signal-to-noise ratio quoted in CCITT or EBU documents is 1 dB higher than that which would be assigned to the same link in the BBC.

