

BBC

ENGINEERING DIVISION

MONOGRAPH

NUMBER 70: OCTOBER 1967

The dynamic characteristics of limiters for sound programme circuits

by

D. E. L. SHORTER, B.Sc.(Eng.), M.I.E.E.

W. I. MANSON, B.Sc.(Eng.)

D. W. STEBBINGS, B.A., Grad.Inst.P.

(Research Department, BBC Engineering Division)

BRITISH BROADCASTING CORPORATION

PRICE FIVE SHILLINGS



BBC ENGINEERING MONOGRAPH

No. 70

THE DYNAMIC CHARACTERISTICS OF LIMITERS
FOR SOUND PROGRAMME CIRCUITS

by

D. E. L. Shorter, B.Sc.(Eng.), M.I.E.E.

W. I. Manson, B.Sc.(Eng.)

D. W. Stebbings, B.A., Grad.Inst.P.
(Research Department, BBC Engineering Division)

OCTOBER 1967

BRITISH BROADCASTING CORPORATION

FOREWORD

THIS is one of a series of Engineering Monographs published by the British Broadcasting Corporation.

About six are produced every year, each dealing with a technical subject within the field of television and sound broadcasting. Each Monograph describes work that has been done by the Engineering Division of the BBC and includes, where appropriate, a survey of earlier work on the same subject. From time to time the series may include selected reprints of articles by BBC authors that have appeared in technical journals. Papers dealing with general engineering developments in broadcasting may also be included occasionally.

This series should be of interest and value to engineers engaged in the fields of broadcasting and of telecommunications generally.

Individual copies cost 5s. post free, while the annual subscription is £1 post free. Orders can be placed with newsagents and booksellers, or BBC PUBLICATIONS, 35 MARYLEBONE HIGH STREET, LONDON, W.1.

CONTENTS

<i>Section</i>	<i>Title</i>	<i>Page</i>
	PREVIOUS ISSUES IN THIS SERIES	4
	SUMMARY	5
1.	INTRODUCTION	5
2.	CONTROL RANGE	5
3.	ATTACK CHARACTERISTIC	6
3.1	General	6
3.2	Duration of Overshoot	6
3.3	Assessment of Distortion due to Overshoot	6
3.4	Limiter Systems Utilizing Delay Networks	9
3.4.1	Current Practice	9
3.4.2	Use of Step-shaping Network	9
3.4.3	Use of Duplicate Variable-gain Stage	10
3.4.4	Determination of Characteristics of Step-shaping Network	11
4.	RECOVERY CHARACTERISTIC	12
4.1	General	12
4.2	Double- and Triple-time-constant Circuits	12
4.3	Choice of Parameters	12
5.	DESIGN OF EXPERIMENTAL LIMITER	13
5.1	General	13
5.2	Variable-gain Element	15
6.	CONCLUSIONS	15
7.	REFERENCES	15

PREVIOUS ISSUES IN THIS SERIES

No.	Title	Date
1.	<i>The Suppressed Frame System of Telerecording</i>	JUNE 1955
2.	<i>Absolute Measurements in Magnetic Recording</i>	SEPTEMBER 1955
3.	<i>The Visibility of Noise in Television</i>	OCTOBER 1955
4.	<i>The Design of a Ribbon Type Pressure-gradient Microphone for Broadcast Transmission</i>	DECEMBER 1955
5.	<i>Reproducing Equipment for Fine-groove Records</i>	FEBRUARY 1956
6.	<i>A V.H.F./U.H.F. Field-strength Recording Receiver using Post-detector Selectivity</i>	APRIL 1956
7.	<i>The Design of a High Quality Commentator's Microphone Insensitive to Ambient Noise</i>	JUNE 1956
8.	<i>An Automatic Integrator for Determining the Mean Spherical Response of Loudspeakers and Microphones</i>	AUGUST 1956
9.	<i>The Application of Phase-coherent Detection and Correlation Methods to Room Acoustics</i>	NOVEMBER 1956
10.	<i>An Automatic System for Synchronizing Sound on Quarter-inch Magnetic Tape with Action on 35-mm Cinematograph Film</i>	JANUARY 1957
11.	<i>Engineering Training in the BBC</i>	MARCH 1957
12.	<i>An Improved 'Roving Eye'</i>	APRIL 1957
13.	<i>The BBC Riverside Television Studios: The Architectural Aspects</i>	JULY 1957
14.	<i>The BBC Riverside Television Studios: Some Aspects of Technical Planning and Equipment</i>	OCTOBER 1957
15.	<i>New Equipment and Methods for the Evaluation of the Performance of Lenses of Television</i>	DECEMBER 1957
16.	<i>Analysis and Measurement of Programme Levels</i>	MARCH 1958
17.	<i>The Design of a Linear Phase-shift Low-pass Filter</i>	APRIL 1958
18.	<i>The BBC Colour Television Tests: An Appraisal of Results</i>	MAY 1958
19.	<i>A U.H.F. Television Link for Outside Broadcasts</i>	JUNE 1958
20.	<i>The BBC's Mark II Mobile Studio and Control Room for the Sound Broadcasting Service</i>	AUGUST 1958
21.	<i>Two New BBC Transparencies for Testing Television Camera Channels (Out of Print)</i>	NOVEMBER 1958
22.	<i>The Engineering Facilities of the BBC Monitoring Service</i>	JANUARY 1959
23.	<i>The Crystal Palace Band I Television Transmitting Aerial</i>	FEBRUARY 1959
24.	<i>The Measurement of Random Noise in the presence of a Television Signal</i>	MARCH 1959
25.	<i>A Quality-checking Receiver for V.H.F. F.M. Sound Broadcasting</i>	JUNE 1959
26.	<i>Transistor Amplifiers for Sound Broadcasting</i>	AUGUST 1959
27.	<i>The Equipment of the BBC Television Film Studios at Ealing</i>	JANUARY 1960
28.	<i>Programme Switching, Control, and Monitoring in Sound Broadcasting</i>	FEBRUARY 1960
29.	<i>A Summary of the Present Position of Stereophonic Broadcasting</i>	APRIL 1960
30.	<i>Film Processing and After-processing Treatment of 16-mm Films</i>	MAY 1960
31.	<i>The Power Gain of Multi-tiered V.H.F. Transmitting Aerials</i>	JULY 1960
32.	<i>A New Survey of the BBC Experimental Colour Transmissions</i>	OCTOBER 1960
33.	<i>Sensitometric Control in Film Making</i>	DECEMBER 1960
34.	<i>A Mobile Laboratory for UHF and VHF Television Surveys</i>	FEBRUARY 1961
35.	<i>Tables of Horizontal Radiation Patterns of Dipoles Mounted on Cylinders</i>	FEBRUARY 1961
36.	<i>Some Aspects of Optical Lens Performance</i>	APRIL 1961
37.	<i>An Instrument for Measuring Television Signal-to-noise Ratio</i>	JUNE 1961
38.	<i>Operational Research on Microphone and Studio Techniques in Stereophony</i>	SEPTEMBER 1961
39.	<i>Twenty-five Years of BBC Television</i>	OCTOBER 1961
40.	<i>The Broadcasting of Music in Television</i>	FEBRUARY 1962
41.	<i>The Design of a Group of Plug-in Television Studio Amplifiers</i>	APRIL 1962
42.	<i>Apparatus for Television and Sound Relay Stations</i>	JULY 1962
43.	<i>Propagational Factors in Short-wave Broadcasting</i>	AUGUST 1962
44.	<i>A Band V Signal-frequency Unit and a Correlation Detector for a VHF/UHF Field-strength Recording Receiver</i>	OCTOBER 1962
45.	<i>Vertical Resolution and Line Broadening</i>	DECEMBER 1962
46.	<i>The Application of Transistors to Sound Broadcasting</i>	FEBRUARY 1963
47.	<i>Vertical Aperture Correction using Continuously Variable Ultrasonic Delay Lines</i>	MAY 1963
48.	<i>The Development of BBC Internal Telecommunications</i>	MAY 1963
49.	<i>Apparatus for Measurement of Non-linear Distortion as a Continuous Function of Frequency</i>	JULY 1963
50.	<i>New Methods of Lens Testing and Measurement</i>	SEPTEMBER 1963
51.	<i>Radiophonics in the BBC</i>	NOVEMBER 1964
52.	<i>Stereophony: the effect of cross-talk between left and right channels</i>	MARCH 1964
53.	<i>Aerial distribution systems for receiving stations in the l.f., m.f., and h.f. bands</i>	JULY 1964
54.	<i>An Analysis of Film Granularity in Television Reproduction</i>	AUGUST 1964
55.	<i>A Review of Television Standards Conversion</i>	DECEMBER 1964
56.	<i>Stereophony: the effect of interchannel differences in the phase/frequency and amplitude frequency characteristics</i>	DECEMBER 1964
57.	<i>Drop-out in Video-tape Recording</i>	JUNE 1965
58.	<i>Sine-squared pulse and bar testing in colour television</i>	AUGUST 1965
59.	<i>The acoustic design and performance of a new free-field sound measurement room</i>	SEPTEMBER 1965
60.	<i>Colorimetric Analysis of Interference in Colour Television</i>	FEBRUARY 1966
61.	<i>Sporadic E Ionization and Television Interference</i>	FEBRUARY 1966
62.	<i>Automatic monitoring</i>	APRIL 1966
63.	<i>The design of transmission lines and single-stage switching circuits for a line-store standards converter</i>	AUGUST 1966
64.	<i>Data for the acoustic design of studios</i>	NOVEMBER 1966
65.	<i>Tristimulus spot colorimeter</i>	DECEMBER 1966
66.	<i>VHF aerial gain calculation using tables of mutual resistance between the radiating elements</i>	FEBRUARY 1967
67.	<i>Pulse Sound: A System of Television Sound Broadcasting Using Pulses in the Video Waveform</i>	MARCH 1967
68.	<i>Recent research on studio sound problems</i>	JULY 1967
69.	<i>A Survey of the Development of Television Test Cards Used in the BBC</i>	SEPTEMBER 1967

THE DYNAMIC CHARACTERISTICS OF LIMITERS FOR SOUND PROGRAMME CIRCUITS

SUMMARY

The monograph describes a series of experiments carried out in order to establish the optimum dynamic characteristics of limiters used to protect transmitters and other equipment in the sound programme chain against overload through excessive signal levels.

It was found impossible, with existing types of limiter, to avoid momentary excessive signal levels at the output unless the gain control was made so rapid in operation as to introduce audible distortion products. To overcome this difficulty, a new type of limiter was evolved, in which a fast-acting servo loop is made to operate a slow-acting gain-control system from which the programme output is taken; the programme input is applied to the gain-control element of the latter with a time delay sufficient to avoid transient overshoot of the signal level.

The gain fluctuations resulting from the operation of a limiter can produce various unaesthetic effects; in the new design, these effects were mitigated by making the effective recovery time-constant vary with signal level.

1. Introduction

It is common practice in sound broadcasting to interpose, at the modulation input of each transmitter, a sound-signal limiter for the prevention of accidental over-modulation. In this limiter, a portion of the transmitted signal, rectified and smoothed, controls a variable-gain element; matters are so arranged that any increase in signal amplitude above a prescribed level is offset by a corresponding decrease in gain, the maximum steady-state output from the system being thus restricted to a constant value. On reduction of the signal amplitude, any lost gain is recovered at a rate sufficiently slow to avoid appreciable waveform distortion of the signal. Limiters of this kind have been used not only on transmitters but also in sound recording and on line-transmission systems, and in recent years have been introduced into individual microphone channels in studios.

The steady-state performance of a sound-signal limiter can be specified without difficulty, and static characteristics closely approaching the ideal can be readily achieved in practice. On the other hand, the transient characteristics of such a device cannot always be described in simple and unambiguous terms, while the performance under dynamic conditions is at best a compromise between conflicting requirements.

The dynamic characteristics of limiters used in the BBC were originally arrived at by empirical adjustment based on conditions obtaining at m.f. transmitters in the 1940 to 1950 period. In more recent years, however, problems, not originally envisaged, arose from the growing practice of utilizing limiters to produce intentional compression effects and from the possible use of several limiters connected in tandem in international music circuits. It was therefore decided, in 1964, to re-examine the subject with a view to specifying the dynamic characteristics desirable in a limiter for use in a modern broadcasting system. In the course of the investigation, it became apparent that some of the desirable characteristics were not obtainable from existing equipment, and new devices were developed to achieve the required end; the

results of this work were eventually embodied in a new type of limiter.

For the present purpose, the transient process of gain reduction—commonly referred to as 'attack'—and that of gain recovery will be considered separately, since, in general, these two aspects of limiter performance may be regarded as independent.

2. Control Range

The primary function of a limiter in a broadcasting chain is to prevent overmodulation of the transmission system by occasional signals of exceptionally high level, the occurrence of which cannot be anticipated by a manual-control operator. From programme level statistics, it appears that only about 1 per cent of the peaks registered by a peak programme meter¹ (P.P.M.) at the studio output exceed the nominal* maximum level for the system, while only 0.2 per cent of the peaks exceed a level 2 dB above this; under normal circumstances, a limiter used for purely protective purposes might not have to operate more often than once every few minutes, producing on each occasion a temporary gain reduction of only a few decibels. On the other hand, limiters are sometimes used to compress the dynamic range of the signal. To this end, the gain of the circuit ahead of the limiter is raised so that the nominal maximum signal level is as much as 12 dB above the point at which limiting commences; the automatic-gain-control action is then continuous over all but the quietest passages of programme. Between these two extremes, the possibility of excess levels due to accidental maladjustment of equipment and the cumulative effect of gain changes in the various links of a programme chain has to be catered for. It was therefore decided that in determining the optimum parameters for a

* The qualification 'nominal' has to be used, firstly because with manual control there is a small but finite probability that this level will be exceeded and secondly because the P.P.M. used for measuring levels has itself a finite time-constant and may not, therefore, indicate the full crest value of the signal waveform.

limiter, any compromise between conflicting requirements should be based on the performance observed with the nominal maximum programme input level set 12 dB above the threshold of gain reduction; in addition, however, the performance of the system was checked at lower input levels.

3. Attack Characteristic

3.1 General

Because of the finite charging time-constant of the signal rectifier and smoothing system which produce the control bias of a limiter, some time necessarily elapses after the arrival of a signal before the appropriate degree of gain reduction is effected; moreover, if the incoming signal waveform includes a pulse having a duration small compared with the charge time constant of the rectifier, the full degree of gain reduction required can never be achieved. Thus, with the rapidly fluctuating signals which occur in the transmission of speech and music, the gain of the limiter—and hence the output signal amplitude—may from time to time exceed the steady-state value which would have been obtained with a constant input level; this effect will be referred to for brevity as 'overshoot'. If the overshoot signal amplitude at the limiter output is greater than the maximum for which the remainder of the transmission chain is designed, audible distortion or interference with other channels may be caused.

3.2 Duration of Overshoot

It seems reasonable to suppose that there is some critical value for the duration of the signal overshoot below which any resulting distortion would not last long enough to be audible, though the figure may be expected to vary somewhat with the amplitude of the overshoot and with the transfer characteristic of the overloaded transmission chain. On the basis of early experience with limiters operating on medium wave transmitters in a purely protective capacity—i.e. without any attempt to compress the dynamic range—the critical time has, in the past, been assumed to be of the order of a few milliseconds, the criterion for adequate limiter performance being that no overshoot should be observable on a standard P.P.M., of which the integrating time* is 10 ms.

In referring to the duration of the overshoot, it is convenient to have some quantitative indication of the time taken by the limiter to perform its function. In this connection, it is common to use the term 'attack time', a single quantity derived, by a process usually unspecified, from the envelope of the output signal obtained when a tone is suddenly applied to the input. In fact, the form of

* The minimum duration of a tone burst required to produce a meter indication 2 dB below that obtained with a steady tone of the same amplitude. The figure given is that which would be obtained with a signal rectifier of 2.5 ms charging time-constant and effectively infinite discharge time, followed by an indicating instrument having negligible overshoot.

the initial transient varies so much between different types of limiter that more than one quantity is required to describe it; for the purpose of this monograph, however, it will be sufficient to use a single quantity T_{A12} , defined as the time taken, after the sudden application of a tone, for an initial 12 dB overshoot at the limiter output to be reduced by 4 dB.†

It is convenient at this point to deal likewise with the definition of a quantity T_{R12} representing the recovery time of a limiter; this will be taken as the time, after the cessation of a signal, required for the gain, after an initial reduction by 12 dB, to return to within 4 dB of its final no-signal value.†

3.3 Assessment of Distortion Due to Overshoot

The initial experiments in the present investigation were aimed at determining the longest permissible duration of overshoot for a limiter operating with a nominal maximum input signal 12 dB above the threshold of gain reduction if the distortion due to the transient overloading of the transmission system is to remain inaudible. To this end, the limiter under test was followed by a circuit having a transfer characteristic designed to imitate that of the transmission system.

In practice, distortion will frequently arise in equipment having a fairly well-defined overload level above which clipping of the signal waveform takes place; to simulate the possible conditions, a full-wave peak clipping circuit was constructed. This was designed to represent a system containing an ideal a.m. transmitter or an amplifier having a high degree of negative feedback, the transfer characteristic remaining in each case substantially linear up to the overload point. Fig. 1 shows the harmonic distortion produced by the clipping circuit as a function of signal level; the clipping level was determined by observing, on a C.R.O., the flattening of the signal waveform.

Fig. 2 shows, in diagrammatic form, the experimental layout. A recorded excerpt of piano music known to be particularly susceptible to clipping distortion was reproduced, via the limiter and clipper circuit, on a BBC standard high-quality monitoring loudspeaker in a quiet listening room acoustically treated to simulate a domestic environment. Ganged attenuators operating in opposite sense were introduced into the system immediately before and after the clipper, and it was thus possible, without altering the reproduced volume, to vary the separation S (dB) between the clipping level and the steady-state maximum output level from the limiter. For each value of T_{A12} , a number of observers were invited, in turn, to find by trial the minimum value of S consistent with the avoidance of audible distortion.

† Following the principles of the current C.C.I.T.T. specification for compressors, the figure of 4 dB, which appears in the definitions of both T_{A12} and T_{R12} , is chosen because, on the linear scale of the C.R.O. used to observe the signal envelope, it represents a point midway between the initial and final amplitudes; in the measurement of recovery time, however, the amplitude observed is that of a tone, too low in level to actuate the control circuits, which is applied to enable the gain to be measured.

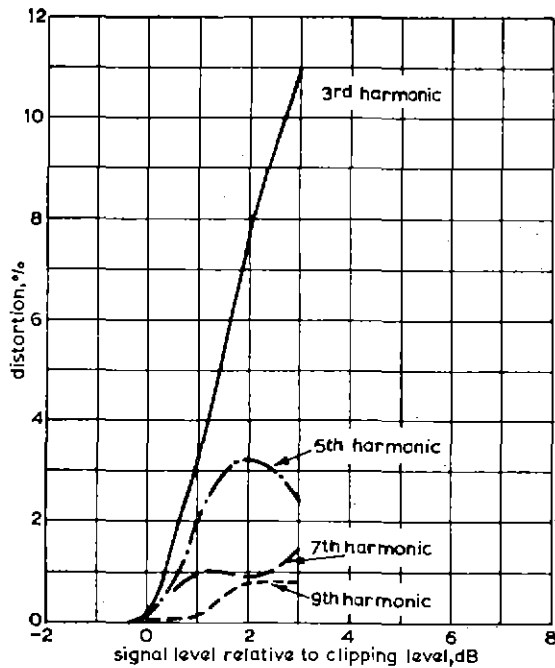

Fig. 1 — Harmonic distortion of clipper as function of signal level

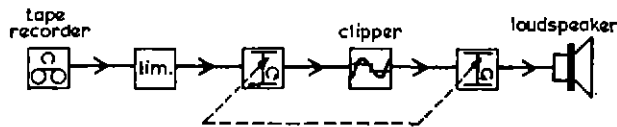

Fig. 2 — Assessment of distortion due to overshoot: experimental arrangement

Fig. 3 shows the relationship between T_{A12} and S obtained* using a BBC standard limiter in which the attack characteristic was modified as required by inserting various values of series resistance in the charge circuit of the control rectifier; the results represent the mean for five observers, and limits representing plus and minus one standard deviation are shown. The recovery time T_{R12} was set at 500 ms.

For values of T_{A12} down to 0.5 ms—the shortest time obtainable with the type of limiter used—the value of S was never less than about 3 dB.

In order to extend the scope of the tests, an existing BBC Research Department limiter design, originally intended for stereophony, was modified to permit T_{A12} to be made as low as 10 μ s. For such rapid operation, special precautions were necessary to prevent any components of the rectified signal in the control system from entering the programme chain, giving the subjective effect of distortion. To this end, particular care was taken to prevent steep-fronted current impulses generated in the control system from entering the common d.c. supply, to preserve symmetry in the push-pull variable-loss circuits up to the highest audio frequencies, and to mount the push-pull transistors concerned in thermal contact so as to minimize drift of balance with temperature. As the limiter had been originally designed for stereophony, the variable-gain stage was duplicated, but for the present purpose, the control signal was derived from only one of these stages; the other was used to provide a check on the amount of any residual breakthrough of control

* These tests were carried out by T. G. Izatt, who also constructed the experimental equipment used.

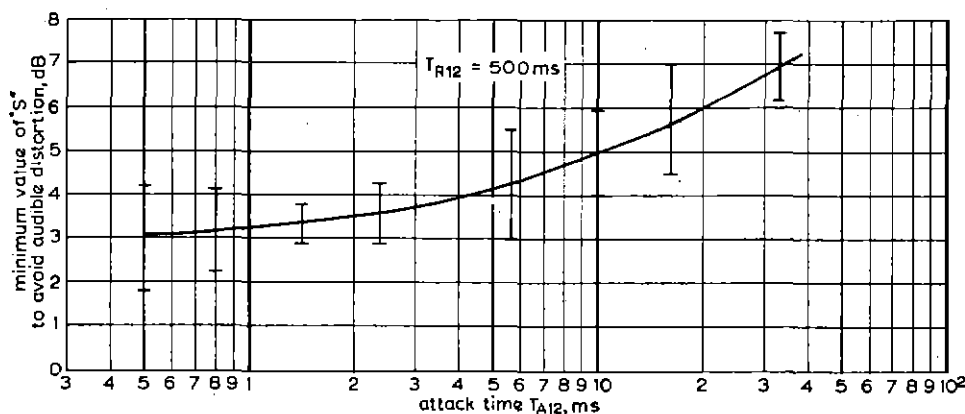

I 2 × standard deviation

Fig. 3 — BBC standard limiter with variable attack time: Relationship between T_{A12} and minimum value of S for no audible distortion

signal under working conditions. Fig. 4 shows the arrangement in block schematic form; VG1 and VG2 are the two variable-gain stages, the gain-bias relationships of which were matched to within 0.1 dB over the working range. The control signal and programme input were

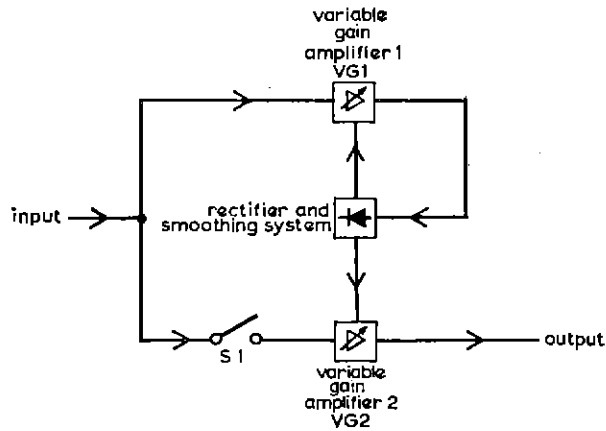

Fig. 4 — Limiter with duplicate variable-gain stage and attack time variable over extended range

applied to both VG1 and VG2 while the programme output was taken from VG2 alone. At any time during an experiment, programme input to VG2 could be interrupted by the switch S1, the gain control action of VG2 continuing to follow that of VG1; any incursion of the control signal into the programme output could then be heard against a quiet background. It was found possible, by careful balancing of the push-pull elements in VG2, to reduce interference from the control chain to such a

level as to be only just perceptible when the gain of the chain after the limiter was increased by 20 dB or more above normal.

The subjective test procedure detailed in Section 3.3 was repeated using the modified stereophonic limiter described above. However, as T_{A12} was progressively reduced, it was found that audible distortion could no longer be eliminated by increasing the value of S or even by removing the clipper altogether—although all other elements in the chain were capable of accepting the full 12 dB overshoot from the limiter without overloading. Breakthrough of the control signal into the programme circuit was demonstrably negligible, and it was therefore concluded that the distortion heard was that due to modulation of the programme by the control voltage; that is, it was a necessary consequence of the rapid change in gain. This type of quality impairment will be referred to for brevity as modulation distortion.

For values of T_{A12} from 0.4 ms upwards, the curve (a) shown in Fig. 5 was obtained; the minimum value of S is again about 3 dB. There was no value of T_{A12} for which the distortions arising from signal overshoot and from over-rapid gain reduction could be simultaneously avoided.

It will be seen that the increase in S with T_{A12} shown as curve (a) in Fig. 5 is more rapid than in the corresponding curve of Fig. 3. The divergence arises from differences in the form of the initial signal transient in the two cases; this factor, already referred to in Section 3.2, does not, however, affect the conclusion of the previous paragraph.

To complete the picture, the effect of varying the recovery time of the limiter was investigated. For curve (a) of Fig. 5 the value of recovery time T_{R12} was 400 ms;

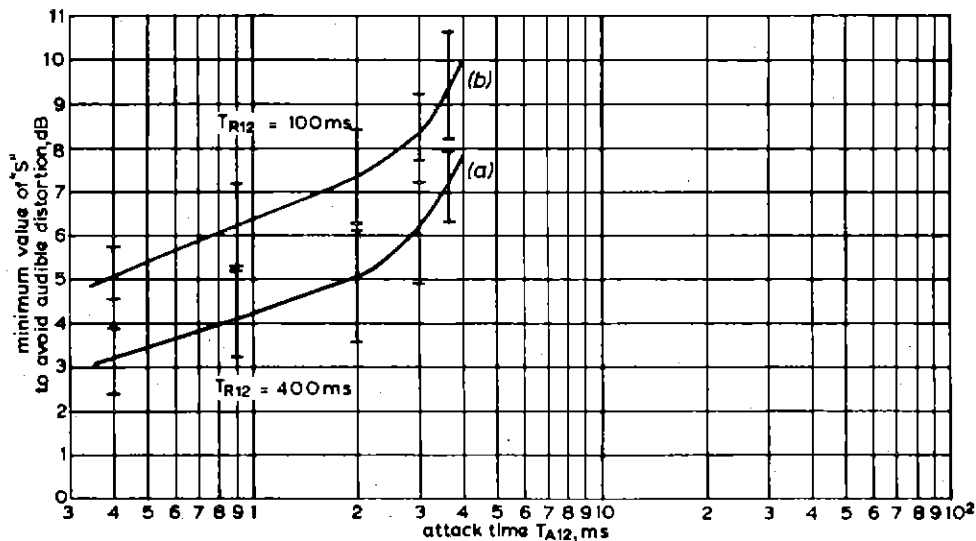

Fig. 5 — Relationship between T_{A12} and minimum value of S for no audible distortion obtained with limiter shown in Fig. 4

(a) $T_{R12} = 400$ ms
(b) $T_{R12} = 100$ ms

▮ 2 × standard deviation

repetition of the subjective tests with T_{R12} reduced to 100 ms produced curve (b). It will be seen that for a given attack time, the effects of overshoot are more pronounced with the shorter recovery time. The explanation of this effect lies in the fact that in the course of the test passage the gain of the limiter rarely returned to its no-signal value; the degree of overshoot produced by a given peak in the signal waveform therefore depended on the gain existing at the time, which in turn was a function of the previous signal level and of the rate of gain recovery.

As indicated earlier, it was originally supposed that the variation of S with T_{A12} would be primarily attributable to variation in the period of time for which the overshoot signal was clipped. However, the results shown in curves (a) and (b) of Fig. 5 could, to a first approximation, have been equally well predicted on the assumption that any signal peak extending beyond the clipping level will produce audible distortion, irrespective of the duration of the excursion. According to this argument, lowering the value of T_{A12} will cause the limiter to operate on peaks of short duration which would otherwise have no effect, so that the average gain is reduced; increasing the recovery time T_{R12} will likewise reduce the average gain. Variation in S with attack and recovery time is then a direct consequence of the resulting variation in average gain.

Whether it be the duration or the amplitude of the overshoot which mainly determines the degree of audible distortion, the conclusion to be drawn from the experimental evidence is the same; for the complete avoidance of such distortion, it is clear that, with the type of automatic gain control under consideration, the overload point of the transmission system must lie several decibels above the steady-state limiting level—a condition which entails an appreciable sacrifice in efficiency and/or signal-to-noise ratio. It would have been possible, by extending the scope of the experiments to other types of programme and by employing a greater number of observers, to establish more accurately the factor of safety required. In the circumstances, however, it was considered more profitable to consider some alternative form of automatic gain control which should be equally effective under dynamic and static conditions, without itself introducing audible distortion.

For the complete avoidance of overshoot in an automatic gain control device, some form of signal delay is necessary to allow time for gain reduction to take place. Possible applications of this artifice are discussed in the next section.

3.4 Limiter Systems Utilizing Delay Networks

3.4.1 Current Practice

Overshoot in a limiter can, in principle, be reduced to any desired extent by introducing an appropriate delay network ahead of the variable-gain element, so that by the time the programme signal reaches this point in the chain, the gain reduction effected by the control circuits is substantially complete. It is clearly essential with this arrangement that the gain control system be operated by

the signal incoming to the limiter and not by the signal at the output. The resulting circuit, which is well known to the art, is shown in block schematic form in Fig. 6.

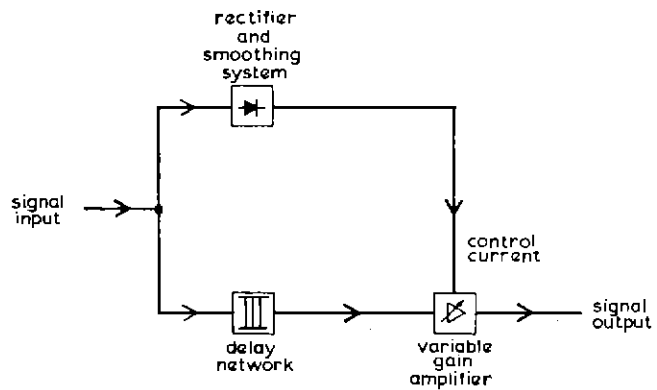

Fig. 6 — Input-controlled limiter with delay network

To eliminate overshoot with all types of signal it is necessary that the rectifier and smoothing system which provides the control voltage for the variable-gain element have a sufficiently short charging time to register fully the crest value of the shortest peak likely to occur—ideally, the shortest peak which the bandwidth of the system will allow to pass. It can, however, be predicted from the bandwidth of the system—and the conclusion has been confirmed by experiment—that in order to meet this requirement with the circuit of Fig. 6, the rate of gain reduction would have to be so great as to produce modulation distortion.

3.4.2 Use of Step-shaping Network

By a slight refinement to the system of Fig. 6 it was found possible to avoid both overshoot and modulation distortion. In Fig. 7, which shows the new arrangement,² the control rectifier system is made sufficiently rapid in action to register the crest value of the shortest incoming pulse. The rate of rise of the control signal reaching the variable-gain element is then restricted by a step-shaping

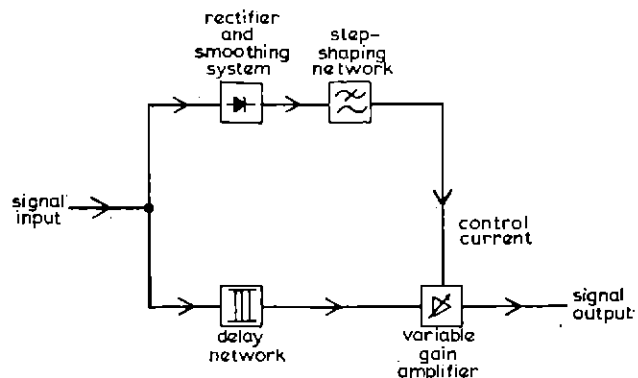

Fig. 7 — Input-controlled limiter with step-shaping and delay networks

network so that the resulting rate of change of gain is not rapid enough to cause audible modulation distortion. To avoid overshoot, the arrival of the signal at the variable-gain element has to be delayed, as before, for a time sufficient for the control signal to reach its full value.

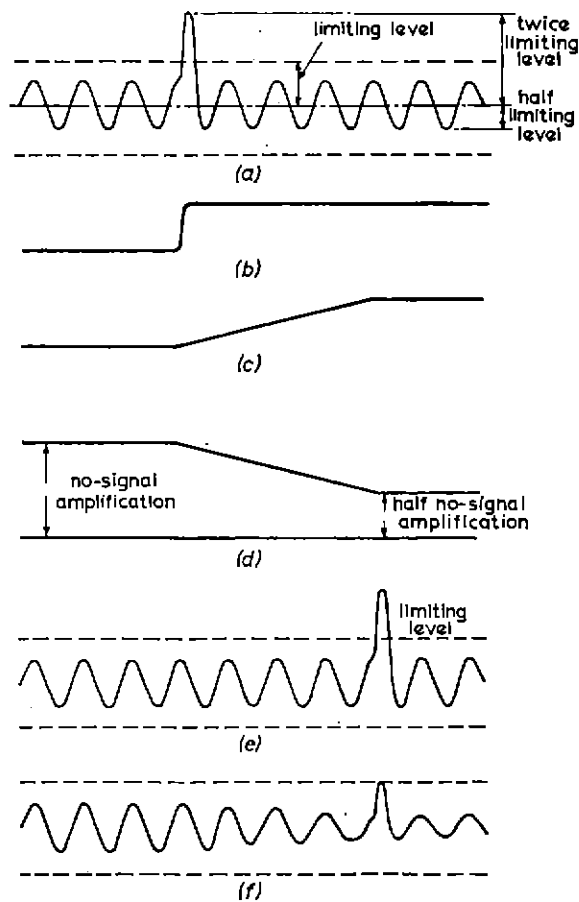

Fig. 8 — Waveforms illustrating the action of the circuit of Fig. 7

Curves (a) to (f) in Fig. 8 show the voltages in various parts of the system of Fig. 7 as a function of time. For the purpose of illustration, the incoming signal, illustrated in curve (a), consists of a sinusoidal voltage together with a single narrow pulse, the rate of rise of which is the maximum possible for the system; for simplicity the amplitudes are made such that if no automatic gain reduction took place, the peak voltages produced at the output of the system by the sinusoidal train plus pulse and the sinusoidal train alone would be respectively twice and half the limiting level.

The control voltage at the output of the rectifier and smoothing system is shown at (b); the charge time-constant of the system is made so short—of the order of $10 \mu\text{s}$ —that the voltage rises in step with the increase of signal above the limiting level, reaching a final value corresponding to the crest of the signal wave. As usual in

practice, the ratio of discharge to charge time-constants is so large that, on the time scale concerned in the present discussion, the discharge of the smoothing capacitor may be neglected.

The control signal from the rectifier passes through the step-shaping network before reaching the variable-gain amplifier. In Fig. 8, curve (c) shows the current at the output of the step-shaping network and curve (d) the resulting change in the amplification of the variable-gain amplifier. The step-shaping network is designed, on the basis of subjective experiments, to allow the required total gain reduction to be effected in the shortest possible time consistent with the avoidance of audible modulation distortion.

Fig. 8, curve (e), shows the signal reaching the input of the variable-gain amplifier after passing through the delay network. The time delay thus produced is made such that the peak in the signal waveform arrives at the moment when the amplifier gain has been reduced to the value required to avoid overshoot.

Fig. 8, curve (f), shows the signal at the output of the limiter. It will be seen that the level of the sinusoidal wave train is reduced in anticipation of the superimposed peak.

It may be noted, in passing, that if variable gain is achieved by the use of slow-acting devices, such as certain types of photo-sensitive element, it may be possible to dispense with part or all of the step-shaping network.

3.4.3 Use of Duplicate Variable-gain Stage

Input-controlled limiter circuits suffer from the practical disadvantage that the form of the output/input characteristic depends on the gain/bias law of the variable-gain element. Ideally, any increase of input signal above the limiting level should bring about an exactly compensating decrease in gain, but, with few exceptions, the required relationship is difficult to achieve. In an output-controlled limiter, on the other hand, the servo action makes the output/input characteristic substantially independent of the gain/bias law of the variable-gain element.

By utilizing the duplicated variable-gain system of Fig. 4, it is possible to produce a limiter circuit with signal delay ahead of the variable-gain element, while retaining the advantage of a servo system. Fig. 9 shows the result of applying this artifice² to the circuit of Fig. 7. As in Fig. 4, the variable-gain amplifier VG1, together with a rectifier and smoothing system designed to respond to the shortest peak in the incoming signal, form a self-contained output-operated limiter, while the programme output is taken from a second variable-gain amplifier VG2. As in Fig. 7, the gain variations of the amplifier from which the programme output is taken are slowed down by a step-shaping network, the time taken to effect gain reduction being compensated by delaying the arrival of the programme signal.

The arrangement of Fig. 9 is not difficult to realize in practice; it is easier to contrive two accurately matched variable-gain elements having an unspecified gain/bias

law than to obtain a single element having the special form of characteristic required for a conventional input-controlled limiter.

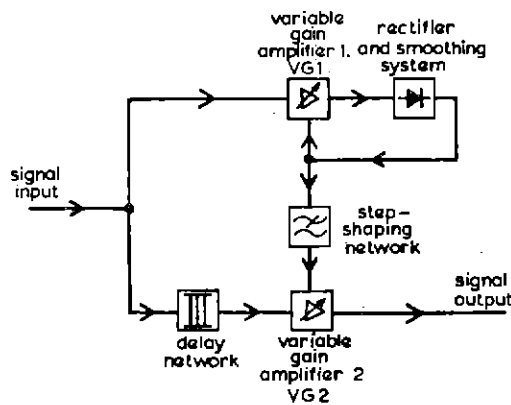

Fig. 9 — Output-controlled limiter with step-shaping and delay networks

3.4.4 Determination of Characteristics of Step-shaping Network

Reference has been made to the design of the step-shaping network on the basis of subjective tests; this procedure will now be described.

To keep the length of the required delay-line to a minimum, it was necessary to choose a form of step-shaping network which allowed the required gain reduction to be effected in the shortest possible time consistent with the avoidance of audible modulation distortion. Subjective experiments were carried out using the simple half-section low-pass filter shown in Fig. 10(a), the step response of which was of the form shown in Fig. 10(b). An overshoot δ of about 12 per cent was allowed; this led to a momentary reduction of the limiter gain to a figure slightly below its steady-state value. Provision was made for varying the time τ which elapsed before the gain first reached its final steady-state value while keeping L/C constant, i.e. without altering the form of the step response.

For the purpose of the tests, the limiter arrangement of Fig. 9 was used, but in the first instance the delay network was omitted; care was taken to ensure an adequate margin of safety in the circuit to avoid overload under transient conditions. The programme material consisted of an excerpt of piano music known to give a clear indication of the onset of modulation distortion; the limiter was 'lined-up' to give a maximum gain reduction, on programme, of 12 dB. In each experiment, the observer compared the output of the test limiter with that of a conventional limiter operating under identical conditions but having an attack time sufficiently long to make the modulation distortion inaudible. Starting with a time τ so short that modulation distortion was obvious, the observer then increased τ gradually and the figure τ_{\min} at which distortion became imperceptible was noted.

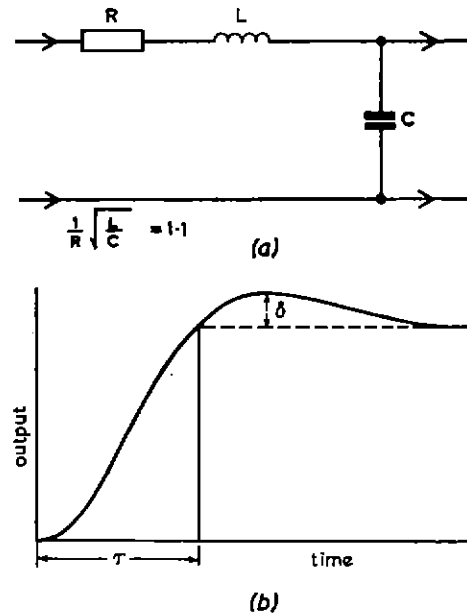

Fig. 10 — Step-shaping network

(a) Circuit (b) Response to unit step

For eight observers the mean value of τ_{\min} was 250 μs , with a standard deviation of 56 μs . The experiment was repeated with networks having step-responses varying from the oscillatory form produced by low damping to the exponential form obtained when $L=0$; all were found to require a longer time to approach the final steady-state than that obtained with the circuit of Fig. 10.

With the introduction of the delay-line before the variable-gain stage, the maximum rate of change of gain occurs just before, instead of simultaneously with, the signal peak initiating the gain reduction. It was thought that in these circumstances less distortion might occur for a given rate of change of gain. The subjective experiments were therefore repeated using an adjustable delay network in conjunction with the step-shaping network of Fig. 10. In each experiment the delay network and step-shaping network were adjusted simultaneously, a small factor of safety against signal overshoot being introduced by making the delay 5 per cent greater than τ . The mean value of τ_{\min} for six observers was 200 μs with a standard deviation of 35 μs . The difference between this result and that obtained without the delay network is in the expected direction and is probably large enough to be statistically significant.

In view of the foregoing, it was decided, in designing an experimental limiter, to adopt a value of τ_{\min} of 305 μs , three standard deviations above the mean arrived at in the last series of experiments; on a 'Normal' distribution, modulation distortion would then be perceptible to less than 0.5 per cent of observers. The corresponding delay time to be provided in the network ahead of VG2 is then 320 μs .

4. Recovery Characteristic

4.1 General

The operation of a limiter may impair the programme quality by the introduction of effects which, while not classifiable as distortion in the ordinary sense of the word, can nevertheless be aesthetically objectionable. These impairments, which increase in severity with the degree of gain reduction, depend largely on the rate of gain recovery with time.

If the gain recovery period extends over several seconds, it will be observed that occasional exceptionally high signal levels, momentary in duration and in some cases making little impact on the ear, produce a sudden and prolonged gain reduction. At the other extreme, if gain recovery is substantially complete within a syllabic period, say 0.2 second, the following effects are apparent:—

On speech, the rise of gain between words, or even between syllables, frequently exaggerates breath noises as well as certain initial consonants. On music, the rise of gain during sustained piano notes or during the natural decay of sound in reverberant surroundings opposes, and may even temporarily reverse, the original fall in level with time. In a sustained choral or orchestral passage, random fluctuations in the crest value of the signal produce corresponding inverse fluctuations in gain, the result being heard as a fluttering effect. The rise in gain at every pause in the programme accentuates background noise, such as studio rumble, tape hiss, or 'print-through'. In the case of a sporting commentary, the level of any crowd noise in the background follows the fluctuations in gain, giving rise to an effect often referred to in the literature as 'gain pumping'.

When the limiter is used as a syllabic compressor, the unaesthetic effects of rapid gain recovery have, of course, to be accepted as the price paid for the increase in average signal level obtainable by this means. The discussion which follows is, however, concerned with the more difficult case of a protective limiter, the function of which, like that of a human operator, is to apply such overall corrections to the programme level as may be necessary to prevent overload of the transmission system, while making the minimum possible change in the short-term dynamic range.

4.2 Double- and Triple-time-constant Circuits

To avoid the more extreme effects described above, it is usual to arrange, as a compromise, for the recovery time-constant of the limiter control circuit to be of the order of 500 to 1000 ms. There is, however, no single relationship between gain recovery and time by which all of the effects described can be avoided, and various attempts have therefore been made to achieve a better compromise by making the effective recovery time-constant vary automatically with the nature of the signal. In one such device, introduced into early BBC limiters, the reservoir capacitor of the control-bias rectifier was made to discharge, through a resistor giving a time-constant of 500 ms, into a much larger capacitor which, in turn, was

discharged through another resistor producing a time-constant of 40 seconds; this arrangement gave, in effect, a double time-constant, the gain-recovery period being automatically prolonged according to the amount and duration of the gain reduction which preceded it. Similar devices have been provided in various commercial limiters. These artifices, while appreciably ameliorating the situation, still fail to bridge the gap between the more extreme requirements, and the present experiments were aimed at extending the range of conditions over which satisfactory operation is possible.

It was found that some of the difficulties associated with a long recovery time could be overcome by making the time-constant dependent on output signal level;³ a recovery time-constant far in excess of that normally permissible can be allowed, provided that the system is arranged to revert automatically to the usual compromise value of 500 to 1000 ms during pauses or quiet passages in the programme.

There remains the problem of achieving a sufficiently rapid gain recovery after the limiter has been operated by a signal of less than syllabic duration, while at the same time avoiding flutter effects on sustained passages. These two requirements are in direct conflict; a useful compromise can, however, be achieved by a double-time-constant circuit having fixed parameters, so designed that whenever the limiter operates as a result of a short duration signal peak, part of the gain is recovered very rapidly, leaving the remainder to be restored at a slower rate.

The circuit arrangement finally adopted* incorporated both the artifices described above, so that the overall effect may be loosely described as that of a triple time-constant. The steps by which the parameters of this system were arrived at will now be briefly related; the values given, which are based on the subjective judgement of the three authors using a variety of recorded programme material, should be regarded as provisional only and are not claimed to represent the optimum compromise in all circumstances.

4.3 Choice of Parameters

Fig. 11 shows, in simplified form, the essential elements of the triple-time-constant circuit. The longest effective time-constant is formed by the product $C_1(R_1 + R_1')$; for programme levels below the prescribed change-over point, R_1' is short-circuited electronically—a process symbolized in Fig. 11 by the switch S1—leaving an intermediate value of time-constant C_1R_1 . The shortest time-constant is formed by C_2R_2 .

It is convenient to consider first the circumstances in which the longest possible recovery time is desirable. Probably the most extreme requirement is represented by a staccato chord played in a concert hall without audience, followed by a pause during which the reverberant sound is heard to die away. For the present purpose, a test passage illustrating this condition was selected from

* The instrumentation of this part of the experimental equipment was carried out by R. L. Deane.

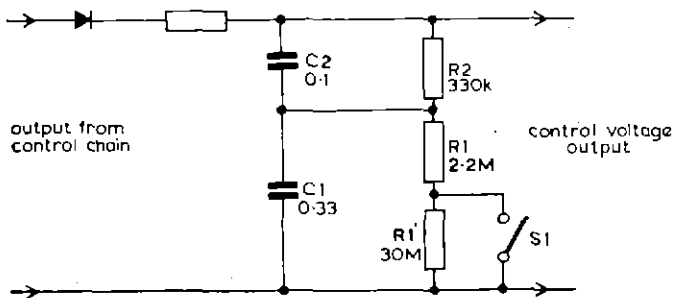

Fig. 11 — Control rectifier system with triple time-constant

experimental orchestral recordings made in St Andrew's Hall, Glasgow; observations were made first with a BBC standard type of limiter which had been modified to allow the recovery time to be lengthened, and later with an experimental limiter of the type shown in Fig. 9. It was found that in order to avoid any audible change in reverberation, the longest time-constant $C_1(R_1 + R_1')$ had to be at least 4 seconds; however, in order to allow for the possibility of the simultaneous operation of two or three limiters in tandem—a condition in which the overall rate of gain recovery with time is greater than that of each limiter alone—this figure was later increased to 10 seconds.

The intermediate time-constant C_1R_1 should ideally be such that the limiter gain is fully restored within the intervals between different speakers in a discussion or interview, but is held at its reduced value as long as the one person continues to speak. As previously indicated, the best compromise is obtained with a time-constant of between 500 and 1000 ms; in the present case, a value of 720 ms was adopted.

The signal level at which the change of time-constant takes place has to be set sufficiently low to avoid appreciably interfering with the 'tail' of a long reverberation process, but not so low that the operation could be upset by background noises. For programmes including classical music covering a wide dynamic range, a suitable change-over point was found to be that at which the output signal falls to 20 dB below the limiting level.

Initial tests using a relay to change the recovery time-constants produced an audible discontinuity on prolonged reverberation; however, a satisfactory compromise was eventually effected by the use of appropriate solid-state circuitry producing a gradual transition.

The function of the short-time-constant circuit C_2R_2 is to avoid prolonged gain depression after a brief, isolated excess signal. The initial division of the control voltage resulting from such a signal is determined by the capacitance values of C_1 and C_2 ,

$$\frac{C_1}{C_1 + C_2}$$

being the proportion of the control voltage developed across C_2 and consequently subject to the rapid rate of

decay associated with C_2R_2 . Certain sibilant speech sounds produce brief but large excess levels and it was found necessary to allow about three-quarters of the control voltage to be discharged quickly, i.e. to make $C_2 = C_1/3$, in order to avoid prolonged gain depression.

If the excess signal is maintained for a sufficient period, the distribution of voltage between C_1 and C_2 changes, at a rate dependent on the time-constant formed by $(C_1 + C_2)$ and

$$\frac{R_2(R_1 + R_1')}{R_1 + R_1' + R_2},$$

eventually the proportion of the control voltage across C_2 becomes

$$\frac{R_2}{R_1 + R_1' + R_2}$$

which, with the restrictions already laid down, is negligibly small. The rate of gain recovery is then almost entirely determined by the long time-constant $C_1(R_1 + R_1')$.

The time taken for the redistribution of voltage is determined almost entirely by R_2 . If the value of this resistor is too high, flutter effects may occur—if too low, gain reduction may be unnecessarily prolonged. The compromise value arrived at by trial was such as to make $C_2R_2 = 33$ ms.

With a recovery time-constant as short as 33 ms, some gain variation during the signal cycle—and hence some waveform distortion—is to be expected at low frequencies. Since, however, the 33 ms time-constant is operative only at the onset of a signal, such effects are transient in character and could not be detected subjectively on any of the available programme material.

5. Design of Experimental Limiter

5.1 General

Figs 12(a) and 12(b) show an experimental limiter based on Fig. 9 and incorporating the gain-recovery circuit of Fig. 11. It is unnecessary for the present purpose to consider the design in detail, but mention will be made of such aspects as may be of general interest.

The servo loop, including the output-controlled variable-gain amplifier VG1, had an attack time T_{A12} of less than 10 μ s. To achieve the necessary speed of operation, the amplitude/frequency characteristic of this part of the circuit had to be uniform beyond the normal audio frequency range, the upper frequency limit being about 180 kHz.

It was found advantageous to provide a meter calibrated in decibels of gain reduction. This was actuated by a signal derived from the variable-gain-element control-voltage and applied to a differential amplifier to eliminate the standing voltage.

The delay network was constructed from ten second-order all-pass sections; the group delay of 320 μ s is constant to within 10 per cent from 0 to 16 kHz.

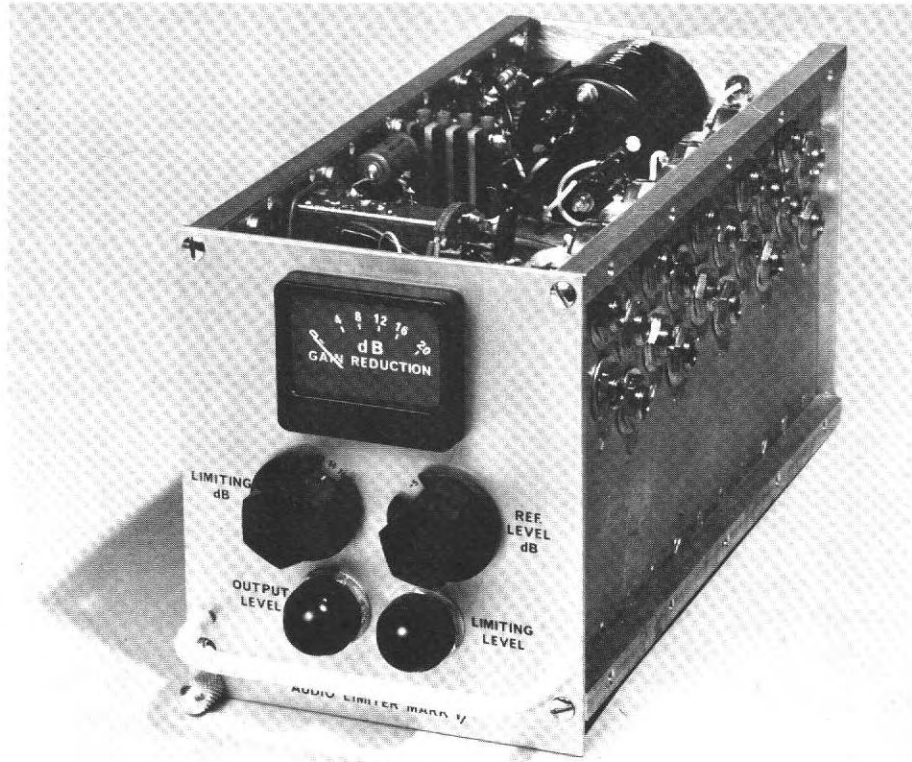

Fig. 12(a) — Experimental limiter; external view

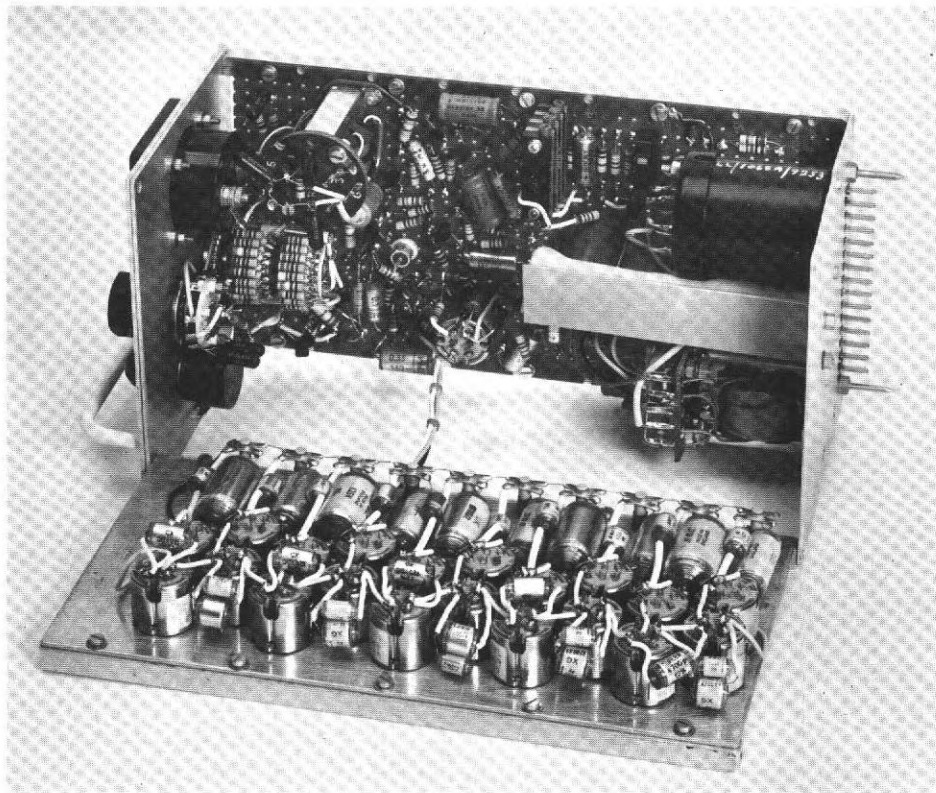

Fig. 12(b) — Experimental limiter; internal view showing delay network

5.2 Variable-gain Element

In the design of a variable-gain element for a limiter it is necessary to ensure that no component of the control signal appears at the programme output. Devices, such as variable- μ valves, diodes or transistors, in which the mean current is varied by the control signal, have therefore to be arranged in accurately balanced push-pull or bridge circuits. Light-controlled variable resistors have been produced which are inherently free from control-signal breakthrough but devices of this kind so far available have a response time of the order of 1 ms, which is too long for use in the fast-acting servo system. For the present purpose, the most convenient form of variable-gain circuit consists of an attenuator including in its shunt arm the source-to-drain path of a field-effect transistor (F.E.T.),⁴ the control voltage being applied to the gate. No d.c. supply is superimposed on the programme signal current flowing in the F.E.T. and the gate impedance is very high; in these circumstances, the mean current between source and drain is zero, and breakthrough of the control signal into the programme output is negligible.

In the experimental limiter, p-channel-type F.E.T.s are used in the variable-gain circuits of both the slow- and fast-acting control systems, the circuit constants being arranged to permit a maximum gain reduction of 20 dB. The current/voltage relationship in the source-to-drain path is non-linear, but the signal voltage across this path was kept sufficiently low to avoid audible waveform distortion.

It may be noted that any distortion produced by the F.E.T. could, if necessary, be partially compensated by applying a portion of the outgoing programme signal voltage to the gate,⁴ though some modification to the circuit would be necessary to avoid control voltages appearing at the programme output. Alternatively, a tetrode F.E.T. could be employed, the control signal being applied to one gate and the compensating signal derived from the programme output to the other.

In order to obtain the required flat-topped output/input characteristic for the limiter, it is necessary that the relationship between control voltage and source-to-drain resistance for the F.E.T.s in VG1 and VG2 be identical.* This requirement was met by selecting the F.E.T.s and by adjusting the values of the resistors associated with them in the variable-gain circuits.

6. Conclusions

It has been found that the control circuits of conventional limiters are not fully effective under transient conditions unless the speed of operation is made so high as to produce audible distortion through modulation of the programme signal. The difficulty has been overcome by a new type of control system involving both fast-acting and slow-acting variable-gain circuits in conjunction with

an appropriate signal delay network. The same artifice could, of course, be applied, where necessary, to compressors and other automatic gain control devices.

The gain recovery characteristics of limiters are also subject to conflicting requirements. Attention has been concentrated on the difficult case in which the overall programme volume has to be regulated without introducing aesthetically objectionable effects through short-term gain fluctuation and a compromise solution, involving automatic variation of the effective recovery time constant over a range of about 300:1, has been evolved. It is possible that similar devices could form the basis for an automatic gain control for unattended studios, though for this purpose some of the recovery time-constants might require to be modified.

An experimental limiter embodying the various features referred to above has been constructed. The opportunity has been taken to explore the potentialities of F.E.T.s as variable resistance elements; these appear to be superior to any of the devices hitherto employed in automatic gain control circuits.

7. References

1. Godfrey, J. W., *Studio engineering for sound broadcasting*, Iliffe Books Ltd, 1955.
2. BBC Patent Application No. 11817/66.
3. BBC Patent Application No. 12733/67.
4. Dasnes, A., and Larsen, F., *Transistorised limiting amplifiers*, *E.B.U. Rev.*, 1965, 89A, pp. 20-3.

* A similar requirement would, of course, arise in the two channels of a conventional stereophonic limiter using F.E.T.s.

© The British Broadcasting Corporation 1967

*Published by the British Broadcasting Corporation, 35 Marylebone High Street, London, W.1. Printed in England
by The Broadwater Press Ltd, Welwyn Garden City, Herts.*

SBN: 563 07363 2